

# E.A.T.: Towards Understanding the Design of Social XR Restaurant Experiences for Diners With and Without Headsets

Yuchen Zheng  
Exertion Games Lab, Department of  
Human-Centred Computing  
Monash University  
Melbourne, Australia  
yuchen.zheng@monash.edu

Hongyue Wang  
Exertion Games Lab, Department of  
Human-Centred Computing  
Monash University  
Melbourne, Australia  
hongyue@exertiongameslab.org

Kenath Perera  
Exertion Games Lab, Department of  
Human-Centred Computing  
Monash University  
Melbourne, Australia  
uduwara.perera@monash.edu

Henryaldi Matio  
Monash University  
Melbourne, Australia  
Hmat0015@student.monash.edu

Florian ‘Floyd’ Mueller  
Exertion Games Lab, Department of  
Human-Centred Computing  
Monash University  
Melbourne, Australia  
floyd@exertiongameslab.org



**Figure 1:** In a future where some diners wear XR headsets while others do not, restaurant dining may enable certain participants to experience XR food augmentations, such as virtual decorations overlaid onto the dish, while excluding others from these experiences. At the same time, XR headsets occlude the wearer’s eyes, potentially disrupting face-to-face social interaction. In this scenario, the diner on the left wears our enhanced headset, which externalizes bodily responses to the shared dining experience through biodata playfully displayed on expressive external screens.

## Abstract

Dining is a social activity, yet human-computer interaction (HCI) research has rarely examined how extended reality (XR) headsets shape shared restaurant experiences. Although XR can augment

taste perception, headsets also obscure facial expressions – particularly pertinent when only some diners wear them. We identify an opportunity to make a wearer’s biodata socially visible via an outward-facing display on the headset to facilitate novel social dining experiences with XR. To explore this, we designed *E.A.T.* (Expressive Augmented Togetherness), a novel XR dining system that combines food augmentation with external displays depicting physiological arousal and pupil movement to facilitate social interactions. Through interviews following a restaurant field study with five groups of three diners, we examined how the system influenced taste perception and social interactions. We identify six design considerations for socially legible XR systems for dining,



This work is licensed under a Creative Commons Attribution-NonCommercial-NoDerivatives 4.0 International License.

*DIS '26, Singapore, Singapore*

© 2026 Copyright held by the owner/author(s).

ACM ISBN 979-8-4007-2563-0/26/06

<https://doi.org/10.1145/3800645.3812856>

ultimately, aiming to inform how HCI can better support social dining experiences.

## CCS Concepts

• **Human-centered computing** → **Interaction design**.

## Keywords

Human-Food Interaction, Extended Reality, Commensality, Embodied Interaction

### ACM Reference Format:

Yuchen Zheng, Hongyue Wang, Kenath Perera, Henryaldi Matio, and Florian ‘Floyd’ Mueller. 2026. E.A.T.: Towards Understanding the Design of Social XR Restaurant Experiences for Diners With and Without Headsets. In *Designing Interactive Systems Conference (DIS '26), June 13–17, 2026, Singapore, Singapore*. ACM, New York, NY, USA, 23 pages. <https://doi.org/10.1145/3800645.3812856>

## 1 INTRODUCTION

Dining out, such as eating in a restaurant, is a popular human activity that often unfolds in social contexts [15, 19, 29, 53]. Research has consistently shown that shared dining positively influences physical health [22] and emotional wellbeing [19, 74], while also strengthening social connectedness [19].

The social interactions that emerge through shared meals are commonly referred to as commensality [53], highlighting the role of eating as a social performance [15]. As interactive technologies increasingly permeate everyday life, commensality itself has been affected. The expansion of the Human-Food Interaction (HFI) field [37, 52] has given rise to the notion of digital commensality, which describes how technologies mediate, extend, or reconfigure social eating practices [69, 71]. Examples range from tele-dining platforms that connect geographically distant diners [26, 78], to artificial commensal companions [45] designed to support individuals that eat alone [21, 56], suggesting that interactive technology can enable new forms of social dining. In this sense, digital commensality is closely tied to the notion of eudaimonia in the digital age, where technologies aim not merely to entertain, but to support meaningful human flourishing [73].

Recent advancements in extended reality (XR) further expand the design space of HFI, including augmenting food appearance [54, 77], enriching sensory perception [80, 81], shaping taste expectations [3, 77], and encouraging healthier drinking behaviors through multisensory design [80]. By allowing to blend visual [3, 13, 77, 80], auditory [80], and embodied interaction [5, 9, 80] cues with physical food, XR enables immersive dining experiences.

Research also has begun to use XR to support commensality. Notable work, such as the *XR Table* [64], explored the use of XR to support social dining across distance, while *Eating Together Apart* [1] does so by designing a multisensory XR dining system in which synchronized eating actions trigger shared environmental changes, fostering embodied co-presence and emergent commensal rituals. Taken together, these works demonstrate that XR can support the perception of meals as well as commensality. However, XR commensality research has so far focused on remote or fully virtual settings [1, 2, 64], leaving the co-located social restaurant experience underexplored.

Moving beyond remote settings toward co-located dining, if XR—particularly headset-based systems—does become a ubiquitous technology, it is plausible that diners may one day wear headsets in restaurants. However, it is important to acknowledge that not everyone will be willing or able to wear an XR headset in such contexts. Prior work on co-located asymmetric XR experiences suggests that asymmetric use of XR headsets frequently emerges in group settings [6, 8, 27, 28, 35], where participants have unequal access to devices. Such asymmetries can be caused by financial constraints [20] and cybersickness [41, 65], exacerbated by the weight and limited ergonomics of current head-mounted displays [14]. Aesthetic and self-presentational concerns may further deter use, as some diners perceive such devices as socially incongruent [59]. Consequently, we propose future social dining scenarios are likely to involve mixed settings in which some participants wear XR headsets while others do not. In such mixed dining settings, situations in which not all participants wear XR headsets can limit non-wearing diners’ ability to perceive wearers’ emotional responses by obscuring facial expressions [34]—signals that could be central to social interaction during social dining [39]. As a result, XR headsets risk functioning as social barriers rather than facilitators of commensality [38]. Although more recent glasses-style XR devices (e.g., Ray-Ban Meta) reduce visual occlusion of the face, they introduce interactional constraints through limited field of view and display framing.

We see an opportunity to use the exterior of the headset to make additional biofeedback of the wearer accessible to others in co-located dining settings. This is inspired by prior work attempts to replicate occluded social cues by externally rendering what is hidden, for example Apple Vision Pro’s *EyeSight* function shows a representation of the user’s eyes on a display on the exterior of the headset. However, we believe that such a replication-based approach is inherently limited by the technical constraints of sensing and display, and are unlikely to ever achieve the full fidelity of unmediated face-to-face interaction. Instead, inspired by prior human-computer interaction (HCI) work that advocates going “beyond being there” [32], we explore more playful, ambiguous—rather than exact representations that we supplement with additional information that is typically invisible, i.e., biodata, that could reveal interesting insights into how the wearer’s body responds to the social restaurant experience (such as excitement when seeing the waiter serving their dish, social banter, or tasting a surprising ingredient).

In order to explore this opportunity, we designed *E.A.T.*<sup>1</sup> (Expressive Augmented Togetherness), an expressive XR dining system that combines food augmentation via a headset for the wearer with two external displays mounted on the outside of the headset that visualize physiological arousal and pupil movement, allowing others to utilize biofeedback-driven emotional responses as social cues for social dining when not everyone wears a headset (Fig. 1). Through this inside-out expressive visualization, we aim to explore the possibility of offering new social signals by externalizing internal affective states as socially perceivable cues, thereby offering new forms of social dining.

<sup>1</sup>The name of our system, *E.A.T.*, is inspired by Experiments in Art and Technology (*E.A.T.*), a not-for-profit organization that historically fostered collaboration between artists, engineers, and scientists.

Through a field study conducted in a restaurant with 15 participants, organized into groups of three who shared two XR headsets while taking turns during a three-course meal, we were able to begin understanding how XR food augmentations and expressive inside-out visualizations shaped taste perception, social interaction, and feelings of connectedness during co-located dining. It is important to clarify that this study does not aim to isolate or quantify the individual contributions of food augmentation versus bio-data visualization. In a real-world restaurant setting, sensory perception and social interaction are inherently entangled. Instead, we position *E.A.T.* as a holistic design probe to explore the emergent user experiences within this multi-faceted XR experience. Our scope is focused on characterizing how these combined experiences co-shape the social dining dynamics, rather than establishing links between specific technical variables and psychological mechanisms.

Overall, this work makes the following contributions to the fields of HFI and XR:

- **The *E.A.T.* System.** We introduce *E.A.T.*, an XR social dining system for co-located commensality. By introducing this inside-out expressive visualizations, we aim to explore how XR headsets can be reframed as social interfaces. We hope this system inspires HFI and XR practitioners to explore more XR experiences for social eating contexts.
- **Exploratory findings.** Through a qualitative study in a restaurant, we were able to derive themes about the user experience when food augmentations combine with externalized affective cues in a restaurant. These findings can be useful for researchers aiming to understand the user experience of combined XR and biodata augmentations in real world settings.
- **Design knowledge.** Drawing on the knowledge developed through the design and study of the *E.A.T.* system, we were also able to derive six design considerations. These considerations aim to provide guidance for design practitioners aiming to create future XR restaurant experiences but do not know where to start.

## 2 RELATED WORK

We now summarize previous works that guided our research.

### 2.1 The use of XR technology in food experiences

The advent of XR technology empowers people to experience “experiences that cannot occur in the physical world” [76]. Building on this concept, Velasco et al. proposed a model for conceptualizing impossible (food) experiences in XR, referred to as the reality–impossibility model [76]. This model provides a conceptual framework for the creation and classification of impossible food experiences through XR by organizing XR experiences along two continuous dimensions (Figure 2):

- (1) **Reality ↔ Fantasy** — whether the objects and environments are based on the real world or imaginary constructs.
- (2) **Laws of Physics ↔ Other Laws** — whether interactions within the experience follow the physical laws of our world or operate under alternative, imagined rules.

Together, these two dimensions form four quadrants (Table 1, Figure 2), each representing a different type of “impossible” food XR experience.

Quadrant 1 (Q1) represents XR food experiences that are grounded in real-world objects and environments and adhere to the physical laws of the real world. Most existing XR food research falls within this quadrant, as it allows researchers to manipulate sensory cues while maintaining ecological plausibility. For example, Wang et al. [77] used virtual reality (VR) to alter the visual appearance of coffee—such as adding “virtual milk” by changing its color—while keeping the physical beverage unchanged, demonstrating that digitally manipulated visual cues can influence flavor perception. Similarly, augmented reality (AR) based systems such as MetaCookie+ [54] manipulate the perceived size or appearance of food items to modulate satiety and consumption behavior without violating physical realism. These studies illustrate how XR technologies can be used to investigate multisensory integration and expectation effects in eating.

Quadrant 2 (Q2) includes experiences that remain anchored in real-world referents but operate under altered or impossible rules, such as violations of causality, time, or contamination norms. A representative example is the study by Ammann et al. [3], in which VR was used to present an emotionally aversive scene—depicting a dog defecating chocolate. Although the food itself was real and unchanged, the impossible visual narrative elicited disgust responses and reduced participants’ willingness to consume the chocolate. Together with studies such as Wang et al. [77], these works demonstrate that XR can shape eating behavior and affective responses by introducing sensory congruence or incongruence that would be impossible to realize in the physical world.

Quadrant 3 (Q3) comprises experiences that introduce imaginary or fictional elements while preserving physical plausibility. Compared to Q1 and Q2, this quadrant has received relatively limited attention in food-related XR research. Such experiences often aim to enrich meaning-making, emotion, or narrative engagement rather than directly manipulating sensory attributes. For instance, “immersiTea” [80] constructs a virtual fictional environment to augment the experience of drinking bubble tea by guiding users through a narrative trajectory closely linked to sensory elements. This work illustrates how Q3 experiences can leverage fictional environments to reshape the meaning and emotional framing of food consumption.

Quadrant 4 (Q4) represents impossible food experiences in which both the setting and the governing rules depart from physical reality. To date, empirical studies of XR food experiences in this quadrant remain scarce. Existing work is conceptual, envisioning speculative scenarios such as eating in outer space [57], or consuming non-existent foods [76].

Across quadrants, we found that most existing XR-based food and dining studies remain situated in laboratory-based, controlled environments, prioritizing internal validity over ecological validity [58, 69, 71]. As a result, these systems are rarely implemented in real-world dining contexts, such as restaurants, where social norms, service dynamics, and spatial constraints fundamentally shape the dining experience. This gap limits our understanding of how XR technologies operate as part of lived, socially situated commensal practices. Our research therefore moves beyond controlled settings

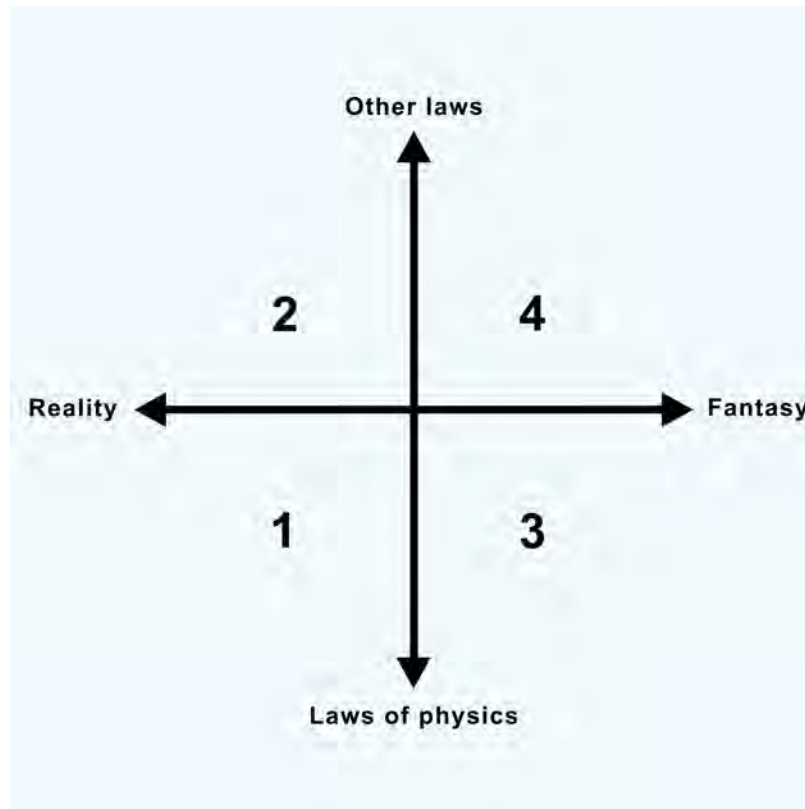

Figure 2: The reality–impossibility model for XR food experiences, adapted from Velasco et al. [76].

to investigate how impossible food experiences in XR function within real-life contexts.

**Table 1: Quadrants of the Reality–Impossibility Model and Their XR Food Implications**

Quadrant	Definition	XR Food Implications
<b>Q1 Physical Reality</b>	– Experiences grounded in real objects and environments that obey physical laws.	Realistic sensory enhancement; prediction and expectation shaping.
<b>Q2 Other Reality</b>	– Real-world referents remain, but time, space, or causal relations are distorted.	Ethically test impossible manipulations on familiar stimuli (e.g., impossible transformations of food, altered gravity).
<b>Q3 Physical Fantasy</b>	– Imaginary elements presented with internally coherent, physically plausible behavior.	Bridges imagination and realism—useful for cultural, emotional, or metaphorical dining design.
<b>Q4 Other Fantasy</b>	– Fully fantastical worlds and interactions that defy all physical constraints.	Enables surreal, metaphor-embodied, or narrative dining worlds.

## 2.2 The potential of physiological signals to mediate social cues in commensality

Dining is not only an individual sensory experience, but also a fundamentally social-perceptual activity [15, 19, 29, 53]. During shared dinings, diners normally attend to others’ micro-expressions, tone of voice, gaze, and bodily cues to infer whether others enjoy the food, feel pleasure, or are engaged in the interaction [75]. This ongoing process of “perceiving that one is being perceived” - often described as reciprocal perception—has been shown to shape subjective eating experiences [63], with the potential to enhance both food enjoyment and social synchrony. Through such mutual awareness, commensality becomes an experience in which affective states and sensory pleasure are socially intertwined. When XR head-mounted displays reduce facial visibility and eye contact, this reciprocal perceptual loop is disrupted. As a result, diners may experience diminished social attunement, leading not only to impaired social interaction but also to reduced subjective pleasure and social satisfaction during eating, we believe. Reconstructing this social perception loop in XR-mediated dining contexts therefore deserves attention, as it directly concerns both social comfort and the quality of the dining experience itself.

Social biofeedback, which leverages physiological signals such as heart rate, skin conductance, and respiration for interpersonal sharing, offers a promising pathway for mediating social cues under

such constraints [50]. In HCI, physiological signals have been explored as non-verbal indicators of affective states and can function as social feedback that helps others “perceive one’s perception”, thereby enhancing emotional transparency and social connectedness [30]. For example, Hirsch et al.’s work has shown that visualizing heartbeats in games can implicitly increase feelings of social connectedness among players, even in asynchronous or non-verbal settings [30]. Within HFI research, systems such as *Living Bento* [11], which map diners’ physiological states onto changes in shared food containers, externalize otherwise invisible affective cues in a form that is socially accessible at the table, thereby demonstrating how sharing physiological signals can foster emotional bonding and social awareness during shared dining.

Together, these examples suggest that physiological signals can operate as socially legible cues when conventional facial and bodily signals are constrained. Among physiological signals, galvanic skin response (GSR) is more commonly used to measure emotional responses to food [72] and dining interactions [48]. Building on this insight, we propose that visualizing diners’ arousal level may help others re-establish access to how they are experiencing the meal, thereby supporting the reconstruction of social perception and enriching commensality in XR-mediated dining contexts.

### 2.3 Gap and research question

Although prior research has examined XR in food-related experiences, XR-mediated social dining in co-located, real-world contexts remains underexplored. In particular, little empirical work has investigated how head-mounted XR devices disrupt social cue perception during shared meals, or how such losses might be mitigated in situ. This gap limits our understanding of XR as part of commensality practice. At the same time, visualizing diners’ arousal levels has shown potential to mediate social perception in XR dining contexts. Building on these gaps, we investigate this opportunity, asking the research question: **How do we design XR co-located commensality experiences to support social dining in restaurants?**

This research question involves a dual focus on both food augmentation (e.g., modifying taste or attention toward the dish) and social interaction (e.g., playfulness, shared interpretation, commensal dynamics), because XR experiences in a restaurant setting inevitably intersect with both the individual’s sensory engagement with food and the collective social dynamics of the meal.

To begin answering this question, we designed and studied the *E.A.T.* system, which we present next.

## 3 DESIGNING E.A.T.

The *E.A.T.* system is composed of three components: XR food augmentations (Fig. 4) experienced by the diner, a custom-designed physical tray (Fig. 5) that ensures stable spatial alignment between virtual augmentations and real food, and the “Eyes” system (Fig. 6) that externalizes the diner’s internal states as a living expression in the shared dining space. Together, these components form an integrated system that couples individual taste perception with socially visible cues to enable a shared multisensory dining experience. To support these components, the experience employs two types of head-mounted displays with distinct roles. A Meta Quest 3 (Fig. 3E) delivers XR food augmentations to the diner, while a

Meta Quest Pro (Fig. 3A) supports both food augmentations and the “Eyes”—expressive external display, enabling the visualization of pupil movement and physiological signals.

### 3.1 Site and meal context

We conducted an on-site visit to the restaurant to ground the system design in an authentic eating context. Based on the preferences of the local community and the restaurant’s most popular offerings, we selected a three-course set consisting of a starter, a main course, and a dessert:

- **Starter:** Beef croquette with garlic sour cream, Japanese curry, tonburi, and beef mince (Fig. 4A).
- **Main:** Wagyu porterhouse (MB8+) steak served with hatcho miso peppercorn sauce and taro crisps (Fig. 4C).
- **Dessert:** Pavlova with Chantilly cream, rhubarb, yuzu sorbet, and pancake (Fig. 4E).

During the visit, we carefully observed and measured the plates used for each course, including their dimensions, depth, rim thickness, and material characteristics. These observations informed subsequent hardware decisions, such as the tray design (Fig. 5), which was dimensioned to fit the plate base to ensure stability and minimize unintended movement or tilt during eating. Importantly, all subsequent XR food augmentations and interaction designs were developed in direct response to the specific dishes, treating the meal as a coherent, situated dining experience rather than a set of isolated visual effects.

### 3.2 XR food augmentations

The XR food augmentations were created in Unity using the Meta XR All-in-One SDK<sup>2</sup>, and deployed on Meta Quest Pro and Meta Quest 3 headsets that supports environmental passthrough. The XR system captures the physical environment including the dining plate, enabling virtual food augmentations to be spatially overlaid onto the plate.

This design slightly reduces the visibility of the real food—as the physical world is mediated through spatial computing rather than direct optical transparency—while still preserving sufficient visual fidelity for diners to eat naturally as they experience the virtual augmentations.

Our design for XR food augmentations is derived from the *Reality-Impossibility Model* [76], introduced in Section 2.1. Inspired by this model, the research team conducted an ideation session. The team consisted of four researchers with expertise in human–food interaction (two PhD students) and human–computer interaction (one undergraduate student, one PhD student). During the session, researchers collaboratively brainstormed ten XR augmentation ideas for each quadrant (see Appendix A, Table 4). These ideas explored how food could be sensorially transformed across varying degrees of reality and impossibility.

After evaluating these ideas based on conceptual coherence (alignment with the meal narrative), perceptual plausibility (how believable the augmentation feels), and interaction potential (how the user engages with the effect), we selected four augmentations

<sup>2</sup><https://developers.meta.com/horizon/downloads/package/meta-xr-sdk-all-in-one-upm/>



**Figure 3: Components of the E.A.T. system: A) a Meta Quest Pro headset used for XR food augmentation and external expressive displays; B) circular external LCD displays with connecting cables for visualizing pupil movement and physiological arousal; C) a portable power bank used to supply external components; D) a GSR sensor with ESP 32 and wiring; E) a Meta Quest 3 headset used for XR food augmentation without external displays.**

for implementation (Table 2, Figure 4). These four XR food augmentations progressively move from the realistic to the fantastical, enabling us to examine how varying degrees of “impossibility” shape users’ multisensory engagement in restaurant.

**Table 2: Four food augmentations for implementation**

Quadrant	Selected Augmentations
Physical Reality (Q1)	<i>Adding salt crystals, cream on top of dessert</i>
Other Reality (Q2)	<i>Steam rising from food</i>
Physical Fantasy (Q3)	<i>The aurora emanated from the food</i>

**3.2.1 The aurora emanated from the food.** This effect introduces an imaginative yet physically grounded augmentation (Q3) for the starter dish—beef croquette (Fig. 4A). The dish’s naturally golden

surface informed the visual language of the augmentation: a warm, yellow aurora-like glow emanates from the food, visually echoing its color while suggesting richness and aroma (Fig. 4B). The aurora, implemented using a Unity particle system, behaves dynamically—subtly flowing along the plate’s contour and responding to ambient motion—creating the impression of a dish that is gently “breathing” with fragrance.

**3.2.2 Steam rising from food.** This XR augmentation was designed for the main course—Wagyu porterhouse steak (Fig. 4C). In everyday dining, visible steam functions as a temporal cue, commonly interpreted as evidence that a steak has just been cooked and is at its peak freshness and flavor. As a meal progresses, these cues naturally fade as the dish cools, signaling the passage of time since preparation. Situated in the Q2, the steam augmentation constructs an impossible temporal illusion of heat and freshness (Fig. 4D).

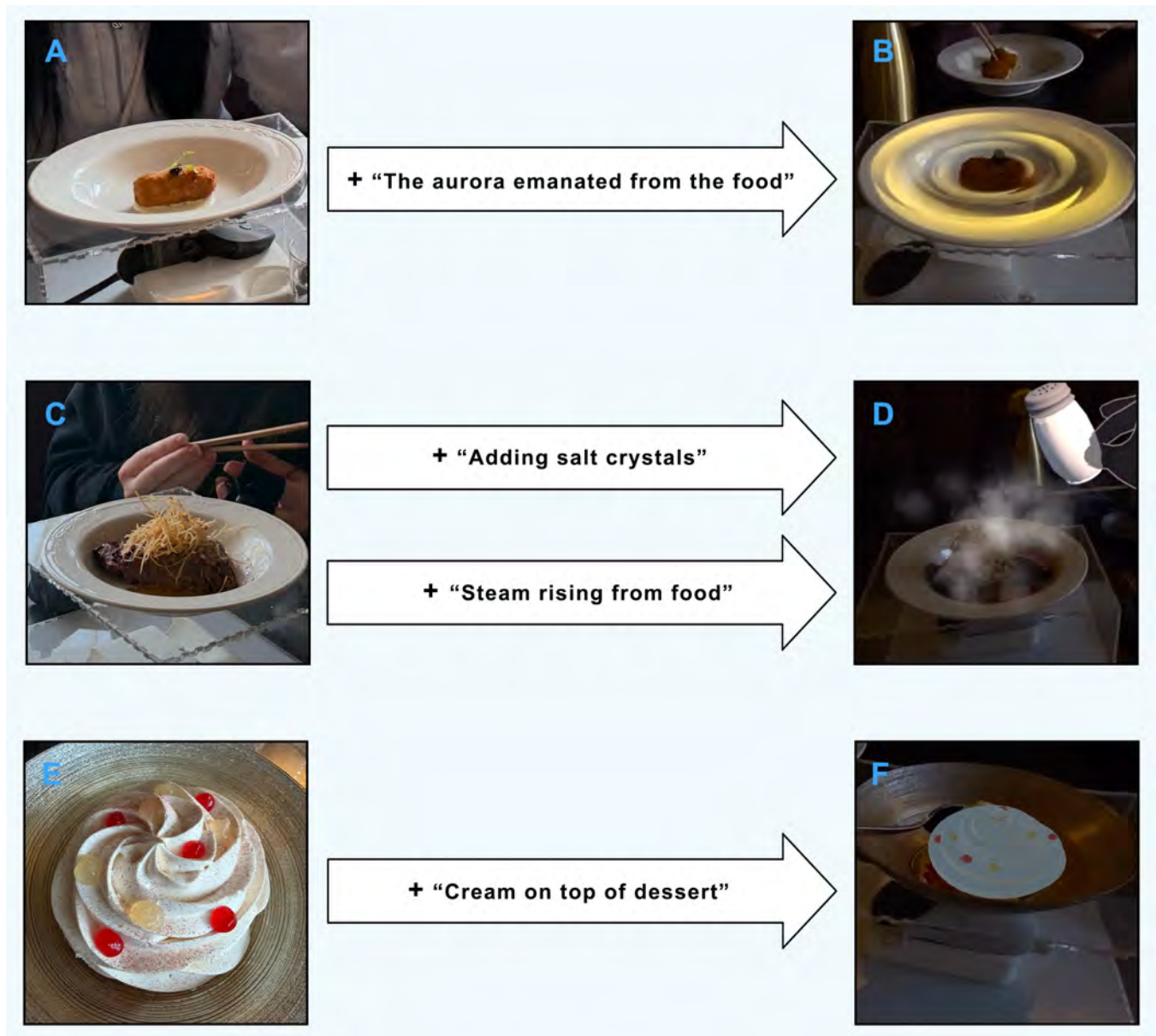

**Figure 4: Physical dishes and corresponding XR food augmentations used in the study: A) starter dish without augmentation; B) starter dish with aurora-like visual augmentation; C) main course without augmentation; D) main course with virtual steam and salt effects; E) dessert without augmentation; F) dessert with a virtual cream layer.**

Semi-transparent vapor, rendered using particle system<sup>3</sup>, continuously rises from the steak and is accompanied by a faint sizzling sound, visually restoring sensory markers that normally belong only to the immediate post-cooking moment. Through cross-modal correspondences between sight, sound, and thermal expectation, the augmentation aims to enhance perceived warmth and liveliness.

<sup>3</sup>[https://gitcode.com/Universal-Tool/c593b/?utm\\_source=article\\_gitcode\\_universal&index=top&type=card&](https://gitcode.com/Universal-Tool/c593b/?utm_source=article_gitcode_universal&index=top&type=card&)

**3.2.3 Adding salt crystals.** Also applied to the Wagyu porterhouse steak, this effect draws from Q1, as seasoning a steak with salt is a common and believable dining action. The augmentation combines visual, auditory, and embodied interaction modalities. Using hand tracking (supported by Meta XR All-in-One SDK), diners can grab and tilt a virtual salt shaker to sprinkle dynamic “salt particles” over the steak (Fig. 4D). The “salt” particles are rendered using Unity’s particle system, allowing the salt to follow realistic gravity-driven fall behavior, accompanied by a subtle sprinkling sound. While the actual taste of the food remains unchanged, the interaction

emphasizes agency and haptic anticipation, reinforcing the ritual of seasoning without altering the physical dish.

**3.2.4 Cream on top of dessert.** This XR augmentation was designed for the dessert course (Fig. 4E). A layer of virtual glossy cream appears on top of the dessert, rendered with light reflection and volumetric shading to simulate its texture and thickness (Fig. 4F). The cream model was derived from the visual form of the restaurant’s pavlova sugar-glaze shell. Situated in the Q1, the design aims to augment perceived sweetness and visual indulgence by visually adding a topping.

### 3.3 Custom physical tray for spatial alignment

To achieve alignment between XR food augmentations and food, the system uses a controller placed within a custom-designed physical tray (Fig. 5D), onto which the dining plate is placed. As shown in the figure, the tray consists of a transparent, box-shaped enclosure composed of acrylic panels (Fig. 5B). A circular opening at the top supports the base of the dining plate (Fig. 5A), ensuring consistent positioning across uses. Inside the tray, directly beneath the center of the plate, a 3D-printed controller dock<sup>4</sup> (Fig. 5C) holds the controller in a fixed orientation (Fig. 5E). The transparency of the clear acrylic material allows the controller’s position relative to the plate to remain visible and facilitates continuous tracking by the headset, ensuring that the controller remains active.

In the Unity implementation, this controller defines the reference coordinate system for placing XR food augmentations. When the controller occupies this predefined position beneath the plate, virtual content, our XR food augmentations, are calibrated to appear at the correct location on the plate surface. Acting as a spatial anchor, the controller establishes the origin for each visual augmentation, ensuring consistent alignment regardless of the user’s head movement or viewing angle.

### 3.4 The "Eyes" system

We chose the circular displays mounted on the exterior of the headset, positioned near the eye area (Fig. 1), to approximate the visual presence of the wearer’s eyes and restore a socially meaningful point of reference during face-to-face interaction. This design is inspired by prior work such as *FaceDisplay* [28] and by commercial devices including the Apple Vision Pro, which place displays near the eye area on the outside of the headset.

The “Eyes” system externalizes the diner’s internal states by integrating physiological sensing, gaze tracking<sup>5</sup>, and real-time visual display—we also call it expressive display. It consists of three primary components: (1) two Waveshare 1.28-inch circular Liquid Crystal Displays (LCDs) that serve as the visual “eyes” (Fig. 3B), (2) a Grove galvanic skin response sensor for estimating diners’ arousal (Fig. 3D), and (3) eye-tracking data captured from the Meta Quest Pro headset to represent pupil movement.

The visual output is presented on the circular displays driven by an embedded ESP32-S3 microcontroller running MicroPython. Physiological arousal is measured using the GSR sensor attached to the diner’s two fingers via a wired analog connection. The GSR

sensor is connected to a ESP32 board, programmed using the Arduino IDE, which transmits processed arousal data to the ESP32-S3 over a WebSocket connection. In parallel, eye-tracking data is sent from the Meta Quest Pro headset to the ESP32-S3 over a WebSocket connection, providing continuous information about the diner’s pupil movement.

All three components communicate wirelessly over Wi-Fi, and during the dining experience they are powered via external power banks (Fig. 3C). The ESP32-S3 merges incoming physiological and eye-tracking data streams and generates a unified, real-time visualization on the circular display, forming the complete “Eyes” interface (Fig. 6). The following subsections detail its two expressive elements: “iris of the eye” and “pupil of the eye”.

**3.4.1 “Iris of the Eye”: GSR visualization.** The iris is the colored part of the eye surrounding the pupil<sup>6</sup>. In the design of our external “Eyes” display, we draw on the colorful characteristic of the iris as a site for conveying subtle emotional variation. We treat the iris area as an abstract expressive surface, suitable for representing internal affective states in a socially legible manner. Based on this design rationale, we map diners’ physiological arousal to dynamic visual patterns rendered within the circular display corresponding to the iris region. Specifically, changes in GSR—a measure of skin conductance that increases with emotional arousal—are translated into evolving colors and shapes on the display.

Before the meal begins, diners wear the GSR sensor, after which the system quietly measures resting GSR for approximately two minutes to establish an individual baseline. This baseline is used to interpret relative changes in arousal during the dining experience. During the dining session, GSR readings are continuously sampled at 10 Hz and compared against this baseline, following prior work on expressive biofeedback systems *Wigglears* [61]. When deviations from baseline exceed predefined thresholds, the circular display transitions through four distinct visual states (Fig. 7), each corresponding to increasing levels of arousal:

- $|\Delta\text{GSR}| < 50 \rightarrow$  Fig. 7A: simple, rounded motifs with smooth gradients and cool tones.
- $50 \leq |\Delta\text{GSR}| < 100 \rightarrow$  Fig. 7B: moderately intricate patterns with soft pulsating lines and gentle warm hues.
- $100 \leq |\Delta\text{GSR}| < 150 \rightarrow$  Fig. 7C: energetic contours with vivid warm tones.
- $|\Delta\text{GSR}| \geq 150 \rightarrow$  Fig. 7D: jagged, complex geometries with saturated colors.

The visual grammar is informed by findings from the *My Daily Badge* workshop [66], in which smooth shapes are associated with positive valence, jagged edges suggest tension, and pattern complexity scales with arousal intensity. Color mapping follows the arousal–valence model [33], gradually shifting from muted to vivid hues as emotional activation increases. The result is a continuously symbol of physiological change.

**3.4.2 “Pupil of the Eye”: eye-tracking display.** While the “iris of the eye” reflects changes in internal arousal, gaze behavior provides a complementary expressive dimension by revealing how attention is distributed during the dining experience [79]. Eye-tracking data from the Meta Quest Pro is captured and transmitted in real time

<sup>4</sup><https://www.printables.com/model/948307-meta-quest-3-controller-dock/files>

<sup>5</sup>[https://github.com/SiiiiWan/Unity6000\\_Meta\\_BaseProject\\_withEyeTracking.git](https://github.com/SiiiiWan/Unity6000_Meta_BaseProject_withEyeTracking.git)

<sup>6</sup><https://www.nei.nih.gov/sites/default/files/2019-06/parts-of-the-eye.pdf>

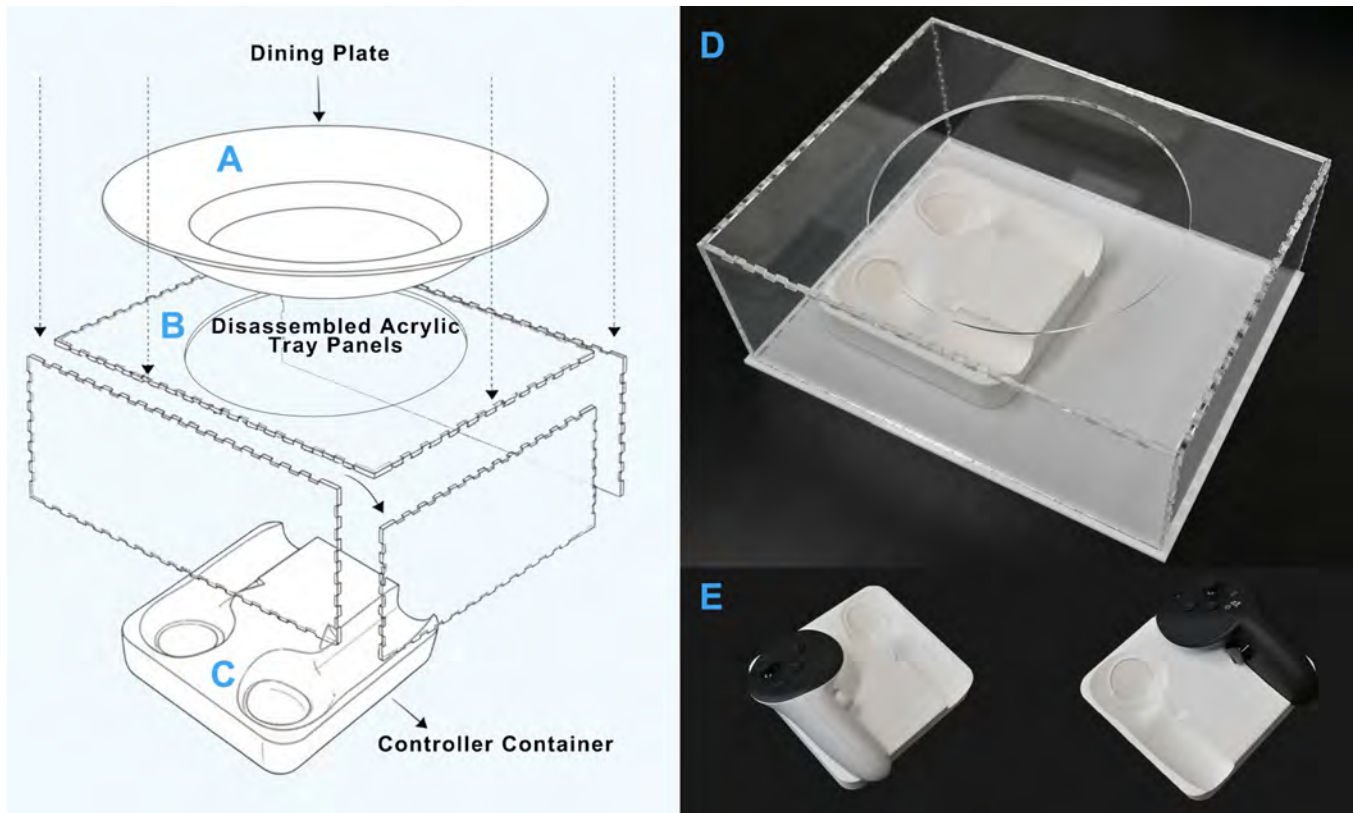

**Figure 5: Custom-designed physical tray for spatial alignment between XR food augmentations and the dining plate: A) the dining plate positioned above the tray; B) disassembled acrylic panels forming the tray structure; C) a dock used to hold the XR controller beneath the plate; D) the assembled transparent tray with the controller dock inside; E) the XR controller seated in the dock.**

to the ESP32-S3. Within the circular display, the position of the central “pupil” follows gaze shifts detected in the headset (Fig. 8). This mapping transforms eye movement into an expressive cue, inviting observers to perceive where the diner’s attention drifts.

#### 4 A STUDY ON EXPERIENCING E.A.T.

We conducted a study to understand the user experience with our system. The study received approval from our institution’s ethics review board.

##### 4.1 Diners

We recruited 5 groups of 3 diners (15 diners in total; aged 24-55 years,  $M = 32.00$ ,  $SD = 10.92$ ; Table 3). 9 diners identified as female and 6 as male; none identified as non-binary or self-described. Each group consisted of individuals who regularly (at least once a year) went out to eat together and were familiar with one another. All diners self-identified as individuals with a strong interest in food. All diners reported no food allergies or dietary restrictions.

Diners were excluded if they reported neurological or vestibular conditions, or prior XR-related discomfort, to ensure safety and comfort throughout the study. Prior experience with XR was not required.

##### 4.2 Study environment and Food

The study was conducted in a restaurant to explore ecological validity and to situate the *E.A.T.* system within everyday dining practices (Fig. 1). A fixed three-course menu (Fig. 4, Section 3.1) was pre-arranged with the restaurant. The restaurant remained open to other customers during our study, and no measures were taken to control for potential disturbances (e.g., background noise, presence of other diners). This decision was made to preserve the ecological validity of the study: the presence of other customers may be related to some participants’ experiences (see Section 5.2.2), highlighting that such “disturbances” are in fact integral to the social dynamics of real-world restaurant dining.

##### 4.3 Procedure

**4.3.1 Pre-meal.** Prior to participation, all diners were introduced to the study and provided with an explanatory statement detailing the study purpose, procedure, and data collection. Written informed consent was obtained from all diners before they were enrolled in the study. Diners then completed a pre-study questionnaire collecting demographic information, prior experience with XR technologies, and information regarding food allergies or dietary restrictions.

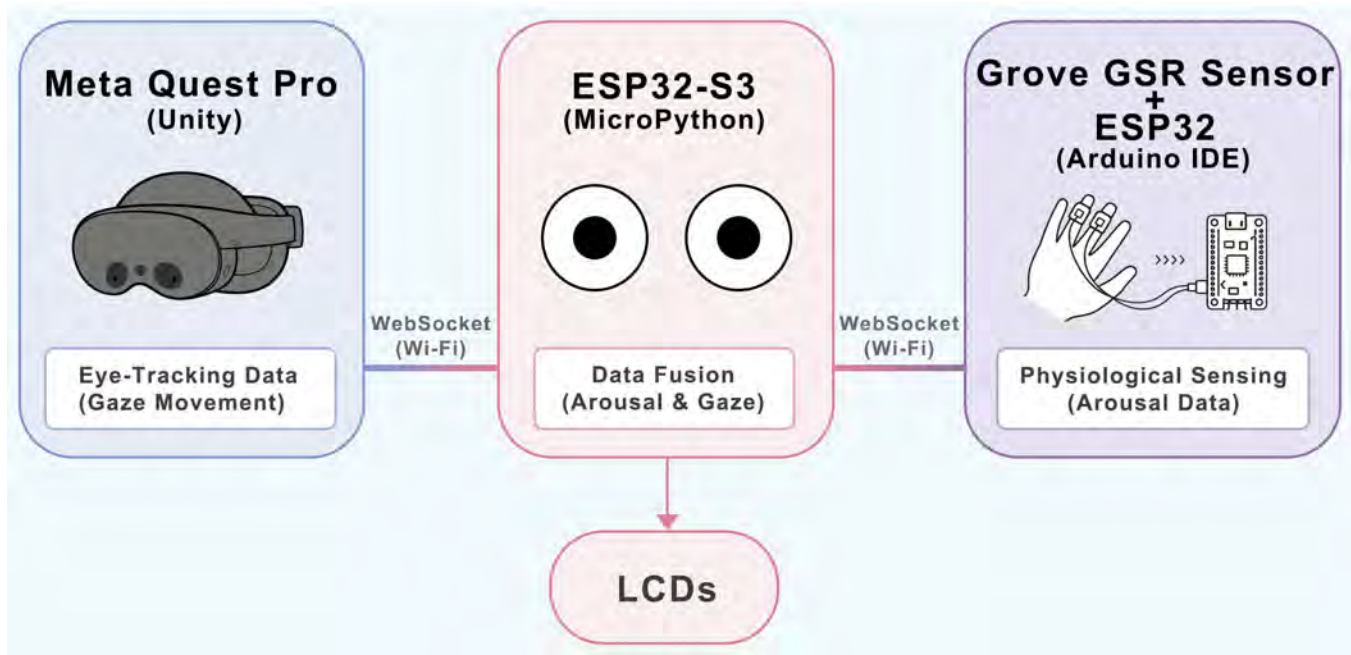

Figure 6: The "eyes" system architecture diagram.

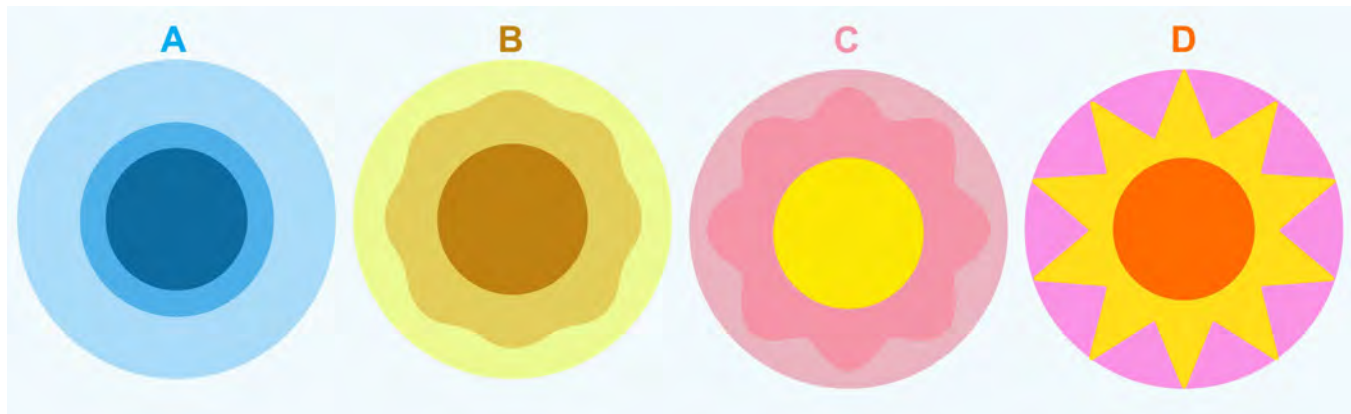

Figure 7: Visual language of the "iris of the Eye," showing four expressive states corresponding to increasing levels of physiological arousal.

Upon arrival at the restaurant, diners were welcomed by the researchers and given a brief verbal overview of the session. Two of the three diners in each group were then fitted with XR headsets. A system calibration phase followed to ensure reliable acquisition of physiological signals. Diners were given a short familiarization period to acclimatize to wearing the headsets before the meal began.

4.3.2 *In-meal.* During the shared meal, diners experienced three setups:

- wearing a Meta Quest Pro headset with XR food augmentation and external expressive displays (Fig. 9A);

- wearing a Meta Quest 3 headset with XR food augmentation but without any external display (Fig. 9B);
- not wearing an XR headset (Fig. 9C).

We chose these setups to examine how diners experience XR food augmentations and interact with co-diners, as well as with other diners and restaurant staff. Reflecting a future in which some people may wear XR headsets while others do not, or may use headsets with different capabilities, each group included one participant wearing a headset with external expressive displays, one wearing a headset that enabled XR food augmentations without external

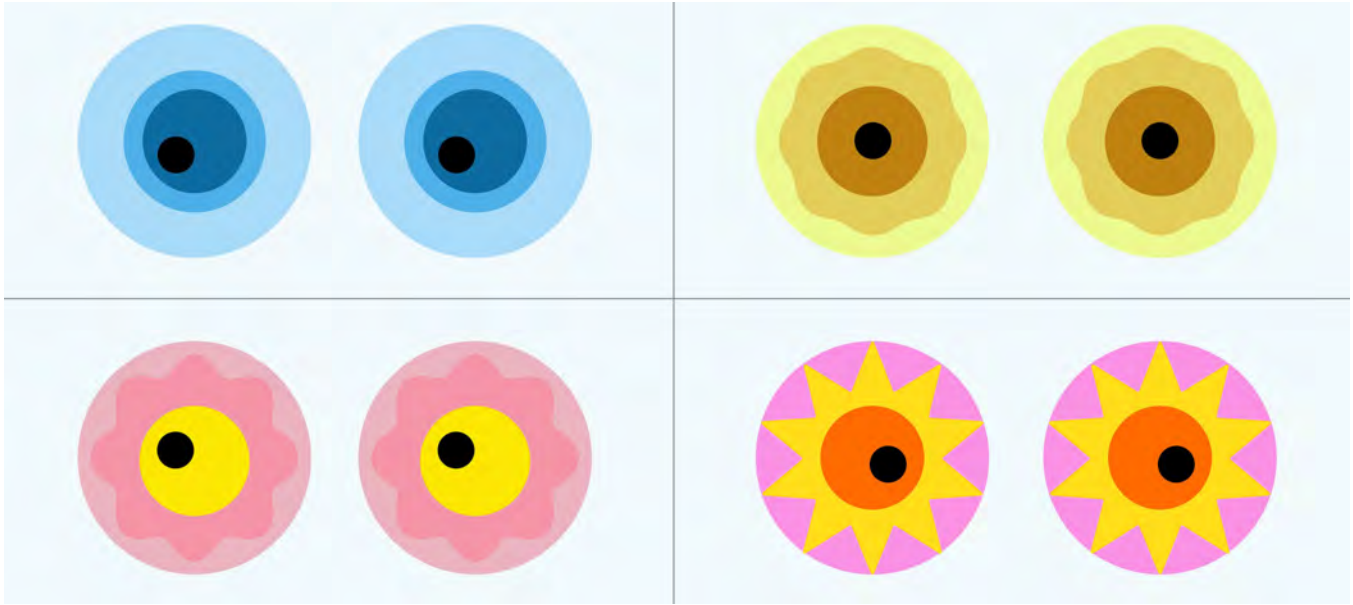

Figure 8: Eye-tracking visualization examples for the “Pupil,” demonstrating how gaze direction is mapped onto the position of the pupil in the external display.

Table 3: Diners’ demographics.

Group	Diner ID (Age, Gender)	Occupation	Relationship
1	D1 (28, F)	PhD Student	Friends
	D2 (24, F)	PhD Student	
	D3 (25, F)	PhD Student	
2	D4 (29, F)	PhD Student	Friends
	D5 (25, F)	Undergraduate Student	
	D6 (27, M)	PhD Student	
3	D7 (26, M)	PhD Student	Friends
	D8 (25, F)	PhD Student	
	D9 (24, M)	PhD Student	
4	D10 (30, F)	Solicitor	Friends
	D11 (29, F)	Solicitor	
	D12 (30, M)	Software Engineer	
5	D13 (55, F)	Food Writer	Friends
	D14 (52, M)	Producer	
	D15 (51, M)	Industrial Designer	

displays, and one wearing no headset. Participants rotated the headsets after each course, ensuring that all participants experienced all three setups.

Diners were encouraged to eat, converse, and interact with one another as they normally would during a shared meal. No explicit tasks or scripted interactions were imposed in order to preserve natural dining behavior.

Throughout the meal, physiological signals were captured continuous. In the expressive XR setup, corresponding visualizations were rendered in real time on the external displays of the XR headsets.

Whenever a diner transitioned into or out of an XR setup involving the external expressive display, a brief recalibration procedure was conducted to ensure reliable physiological signal acquisition and accurate mapping between signals and visualizations.

*4.3.3 Post-meal.* Each group of diners was afterwards invited to a semi-structured group interview (approx. 60 minutes). The micro-phenomenology interview technique [62] was applied to capture subjective experience. The emphasis lied on experiential dimensions such as thought, perception, and sensation [60]. Interviews were



**Figure 9: In-meal study setups: A) wearing an XR headset with external expressive displays; B) wearing an XR headset without external displays; C) not wearing an XR headset.**

audio-recorded and later transcribed for analysis. Diners could skip questions or terminate the interview at any time. Finally, diners were thanked for their participation.

#### 4.4 Data analysis

We conducted a reflexive thematic analysis [7] through a three-stage analytic process. In the first stage, NVivo 15 was used to support initial coding, with each question–answer pair treated as a single analytic unit. Two researchers familiarized themselves with the data through repeated reading and reflexive memo-writing, generating an initial set of codes grounded in the data.

In the second stage, the coding outputs from NVivo were exported to a collaborative online whiteboard (Miro), where codes were visually organized, compared, and clustered through iterative discussion.

In the final stage, we reviewed and refined all coded units, retaining 118 analytic units that were relevant to the research questions. Through this iterative process, five themes were developed; this paper focuses on three themes that directly relate to our research question.

To complement the thematic analysis, we conducted a parallel review of the video recordings we took with participant consent during the meals to observe behavioral indicators, such as eating patterns, social interactions, head and hand movements. While these behaviors were not formally coded, they informed our interpretation of attention, bodily engagement, and system responsiveness.

## 5 FINDINGS

We now present our findings (F) through the following 3 themes:

### 5.1 Theme 1: Shaping experiential engagement through XR food augmentation during dining

Across groups, diners articulated a boundary between XR visual augmentations and bodily gustatory sensation. As D2 remarked, despite seeing salt being added, she “*knew it was virtual*,” and therefore did not experience the food as saltier. Similar observations were reported by D3, D9, D10, and D14, who described the virtual cream as visually present yet detached from their embodied tasting experience.

Despite recognizing the limited effectiveness of the augmentations for altering taste, diners described shifts in attention, expectation, affective experience, and playful engagement during dining.

**5.1.1 F1. Visual augmentation reorganized attentional focus around the dish.** Diners described changes in how the dish was foregrounded as an object of attention during the meal. We observed that with visual augmentations such as the glowing effect on the starter, diners looked longer and more closely at the plate and the food itself. D7 likened the effect to aroma becoming visible, describing it as “*the smell of the food coming out in waves*,” which intensified attention toward the dish when combined with its real scent (D7). One interpretation is that, in these moments, the augmentation may have functioned primarily to redirect where attention was placed, rather than to change what the food was understood to be.

**5.1.2 F2. Multisensory interaction guided diner’s anticipatory engagement.** When visual and auditory cues were combined—most notably in the main course augmentation featuring rising steam accompanied by sizzling sounds—diners described the dish as appearing “*freshly prepared*” (D9) or “*more appealing*” (D3). We observed that these impressions emerged even as diners emphasized that the food did not taste hotter or different during consumption. D9 articulated this temporal layering clearly, distinguishing between multiple experiential phases: first “*noticing the sound and steam*”;

then interpreting these cues as signaling that the food would be “*more delicious*” and “*emotionally satisfying*”; and finally realizing during eating that the food itself was not actually hotter. For D1, contextual factors amplified affective weight, as she described an immediate sense of comfort and happiness when encountering “*the steam effect on a cold day*”, noting that it made the dish feel “*especially satisfying*”.

We also observed that augmentations that incorporated bodily interaction further intensified engagement. The “adding salt crystals” augmentation, which combined visual effects (virtual salt crystals), sound (the sound of sprinkling salt), and bodily movement (grasping a virtual salt shaker and sprinkling salt), was consistently described as more engaging than purely passive visual and auditory effects. The researcher observed that D6 repeatedly sprinkled salt while waiting for the dish; in the interview, he framed the interaction as a “*playful occupation*” during moments of waiting. D3 was the only participant who reported a slight perceived impact on taste, attributing it to the fact that she actively performed the action of sprinkling salt, supported by synchronized visual and auditory feedback: “*the salt effect perfectly matches how I normally use a salt shaker, how I grab it, give it a couple of shakes, and then every time I shake it downward, the salt grains come out very precisely [...] the sound design is closely resembles that familiar click-click sound you get from the kind of salt shakers we usually use in everyday life.*” Based on this, we could say that agency and embodied actions appear to modulate how diners attribute meaning to XR interactions.

**5.1.3 F3. Playfulness triggered shared moments.** Beyond individual perception, we found the XR augmentations appeared to enrich the social atmosphere of the meal by introducing playfulness and shared moments of amusement. Diners frequently described the experience as “*playful*” (n=6), “*interesting*” (n=7), and “*fascinating*” (D13), often emphasizing its novelty. As D10 noted, wearing an XR headset during a meal was itself a “*rare*” and “*memorable experience*”. From researchers’ observation, these playful qualities sometimes redirected attention toward other diners. For example, in Group 1, during the main course, D2 playfully “sprinkled” virtual salt onto the head of a non-headset-wearing diner (D1), knowing that D1 would not be aware of what was happening and treating the action as a playful prank. Another headset wearer, D3, recognized the action and joined in the laughter, with D2 remarking, “*It was super funny.*” We interpret this as suggesting that, in such moments, the augmentations might function as a shared social prop and that they may have facilitated playful interaction.

However, diners also reflected critically on the longevity of this effect. D2 questioned the sustainability of the experience, noting that while it was enjoyable as a one-off novelty, familiarity quickly diminished its appeal: “*I wouldn’t want to play with it again next time.*” This highlights a tension between novelty-driven engagement and long-term experiential richness, suggesting that maintaining playfulness in XR dining may require greater diversity, adaptability, or narrative progression rather than static effects.

## 5.2 Theme 2: Supporting social interaction through visible affective cues in restaurants

Across groups, diners (D1, D2, D3, D4, D7, D8, D9, D10, D11) interpreted the external display as a new layer of affective legibility that shaped social coordination and mutual awareness during the meal. Specifically, D2 described the external display as contributing to the atmosphere of the meal, noting that it could “*bring up the mood*” and “*make the meal more fun.*” D6 framed it as an opportunity for mediated self-expression, describing the external display as something that could “*express for me.*” D3 emphasized the loss of conventional cues caused by XR headsets, explaining that without the external display, it became harder to infer others’ states: “*Even if I look at her, I can only see whether she’s smiling or not [...] I can’t see her eyes.*” These accounts suggest that the external display functioned as a compensatory social layer, partially restoring legibility when facial cues were obscured. We identified four interrelated findings that illustrate how the affective interface reshaped social scenarios during dining:

**5.2.1 F4. Expressiveness of display.** From examining the videos, we observed that the external display frequently changed color in response to both sensory and social stimuli. For example, the external display of D12 turned to visual state 4 (Fig. 7D) when tasting the sour dessert, while similar state changes also occurred during moments of animated conversation. D7 described how the external display became an expressive tool for others: “*Others can know what state you’re in right now through the display, whether you like the dish or not.*” We also observed that in Groups 1 and Group 4, diners used the displays as conversational material, joking about or teasing each other based on the external display. For example, Group 4 appropriated the display for playful gossip, turning it into a “trigger game” in which diners without external display collectively observed how the “eyes” display wearer (D11) responded when different people and different event were mentioned. When D11 heard a person’s name and the display color suddenly changed to the high arousal visual, D10 started teasing her about why she was reacting so strongly to that person.

However, the expressiveness of display was not immediately obvious. D4 reflected that the external display felt “*more like a bodily extension, not the real eye,*” and importantly, its emotional meaning was unclear at first. Over time, D4 gradually learned the mapping between display changes and lived experiences, the external display became “*fun*”. This suggests that interpretability of affective interfaces in dining contexts emerged through social interaction.

Furthermore, diners also noted limitations in the emotional range conveyed by the display. D2 pointed out that the color mapping primarily represented calm-to-positive states: “*Because the blue [on our display] represents a normal state, and then ‘happy,’ ‘happier,’ and ‘super happy,’ but it seems there isn’t anything for ‘unhappy’ [...] so it feels like this system can only convey happy states or positive emotions.*” In contrast, her co-diner, D3, perceived this limitation as appropriate for the dining context, remarking that such a display “*fits well with eating together.*”

**5.2.2 F5. Affective visibility raised concerns about boundaries.** Although the external display appeared to increase social legibility,

diners repeatedly emphasized the importance of boundaries around affective visibility, particularly in restaurant settings.

Among friends, the external displays were described as “playful” (D7), “acceptable” (D1, D4), and “interaction-promoting” (D1, D3). Yet even within close relationships, D8 felt that physiological visualization could be “too revealing”, exposing thoughts or reactions they preferred to keep private. With strangers, concerns could be intensified. For example, D3 described feeling uneasy about being looked at by diners at neighboring tables, likening the experience to being “an animal in a zoo.” She explicitly rejected attention from strangers, stating, “If it’s a stranger [...] I really hate it. [...] Don’t look at me!” Although she noted that strangers might not yet understand the meaning of the display, she emphasized that once these meanings became common knowledge, the visualized reactions would feel like “very private information.” To mitigate this discomfort, D3 suggested placing the external displays on the table (Fig. 10), where they would be visible only to dining companions and thus feel more socially comfortable.

Diners also raised concerns about exposing their biodata to restaurant staff. D9 speculated that owners or servers might interpret calm or muted displays as dissatisfaction, effectively turning the external display into an implicit feedback channel: “For the restaurant, this is actually a good thing—it gives them feedback from customers [...] If everyone reacts very mildly to a dish, it probably means the dish is rather unremarkable.” While such feedback might appear efficient, diners described it as potentially transforming the experience into one of being monitored rather than cared for, as D8 put it succinctly: “I wouldn’t want them to see that [the external display].”

At the same time, three diners (D6, D7, D9) valued the way the headset obscured their real facial expressions. D6, for instance, described the external display as a protective mediator: “I feel like I can hide behind it.” For him, the display acted as a substitute agent—“a little robot that connects with others for me”—allowing connection without full exposure. Together, these accounts suggest that affective interfaces for dining must carefully negotiate intimacy, visibility, and situational appropriateness.

**5.2.3 F6. Uneven distribution of expressive visibility reshaped participation.** All diners (D1–D15) pointed out that the XR headsets already introduced a degree of social isolation, even though they had the pass-through functionality. For example, D4 said, “once I put it on, I was just eating my own food by myself.” The uneven distribution of expressive visibility was associated with imbalances in participation. As D3 noted, individuals wearing the expressive display often became focal points in interaction, “as if whoever has the display automatically gets more attention,” while non-wearers risked becoming socially “transparent,” contributing less visibly to the shared exchange. D12 linked this spotlight effect to personality differences, suggesting that people who “seek attention” might welcome the display. We speculate, for diners who preferred to remain quiet or observe, such heightened attention could be uncomfortable, particularly in mixed groups with differing levels of social confidence.

Together, these dynamics suggest that affective interfaces for dining do not merely reveal emotions; they actively reconfigure

patterns of participation by redistributing who is seen, interpreted, and responded to during shared meals.

**5.2.4 F7. Spatial configuration relocated affective cues into the shared dining space.** We observed that diners actively experimented with the two external displays to better align affective expression with the dining scenario during study, indicating that form, placement, and playfulness can meaningfully shape how the interface is integrated into shared meals. While researchers initially positioned the displays near the location of the wearer’s real eyes (Fig. 9A), diners (D6–D15) altered this configuration. For example, D6 intentionally repositioned the two external displays in a playful arrangement (as shown in Fig. 10B), explaining that this repositioning contributed a “sense of humor” and made him feel more at ease at the table.

D8 explored spatial redistribution across the table, placing one display on the table and the other on their head (as shown in Fig. 10C), using the former for self-observation and the latter for social sharing: “One ‘eye’ on the table lets me see how my emotions change when I eat, and the one on my head lets others see it.” In another case, D9 placed both displays on the table: one closer to himself and one at the center (Fig. 10A). D7, a dining partner seated opposite D9, reflected that the table-placed display drew more attention, noting that “when you’re eating, you’re usually looking down, so it’s easier to notice the one on the table.” This suggests that table-level placement may better align with natural eating posture, making affective cues more accessible during the meal.

### 5.3 Theme 3: Diner comments

Across groups, diners articulated a set of complaints in which XR experiences were perceived as sources of disruption during eating, interfering with their ability to see (D1, D2, D3, D4, D5, D6, D8, D9) and comfortably consume food (D1, D2, D6), as well as to maintain ordinary social engagement at the table (D2, D3, D7, D13).

**5.3.1 F8. Augmentation obstructed visual access of food.** Multiple diners (D3, D5, D9) reported that XR visual augmentations and headsets’ pass-through feature interfered with their ability to clearly see and assess food during eating. D3 described how the headset disrupted her routine visual inspection of the dish, preventing her from identifying texture, color, and ingredients prior to consumption: “It still affects my field of view [...] I can’t clearly observe the texture of the steak [...] I can’t really tell what ingredients are in it [...] I have to eat it [to know] what it’s made of, which is not a good influence.” D5 echoed this sense of obstruction, stating that “I didn’t really know where my mouth was,” which made it difficult to judge distance while eating. During the dessert course, D9 described the virtual cream layer as blocking their view of the physical food beneath, noting, “I wanted to lift it away.”

**5.3.2 F9. Camera-mediated XR headset interfered with social engagement.** Beyond eating itself, diners also described head-mounted displays as disrupting social engagement at the table. D3, for instance, noted that without a headset, she could look at her companions while eating, whereas with the headset she was forced to focus on the food and utensils: “Normally I can eat without watching the food [...] today I have to stare at the food and my chopsticks to get it into my mouth.” From the perspective of non-wearing diners, this shift was experienced as a sense of social disconnection. D2 described

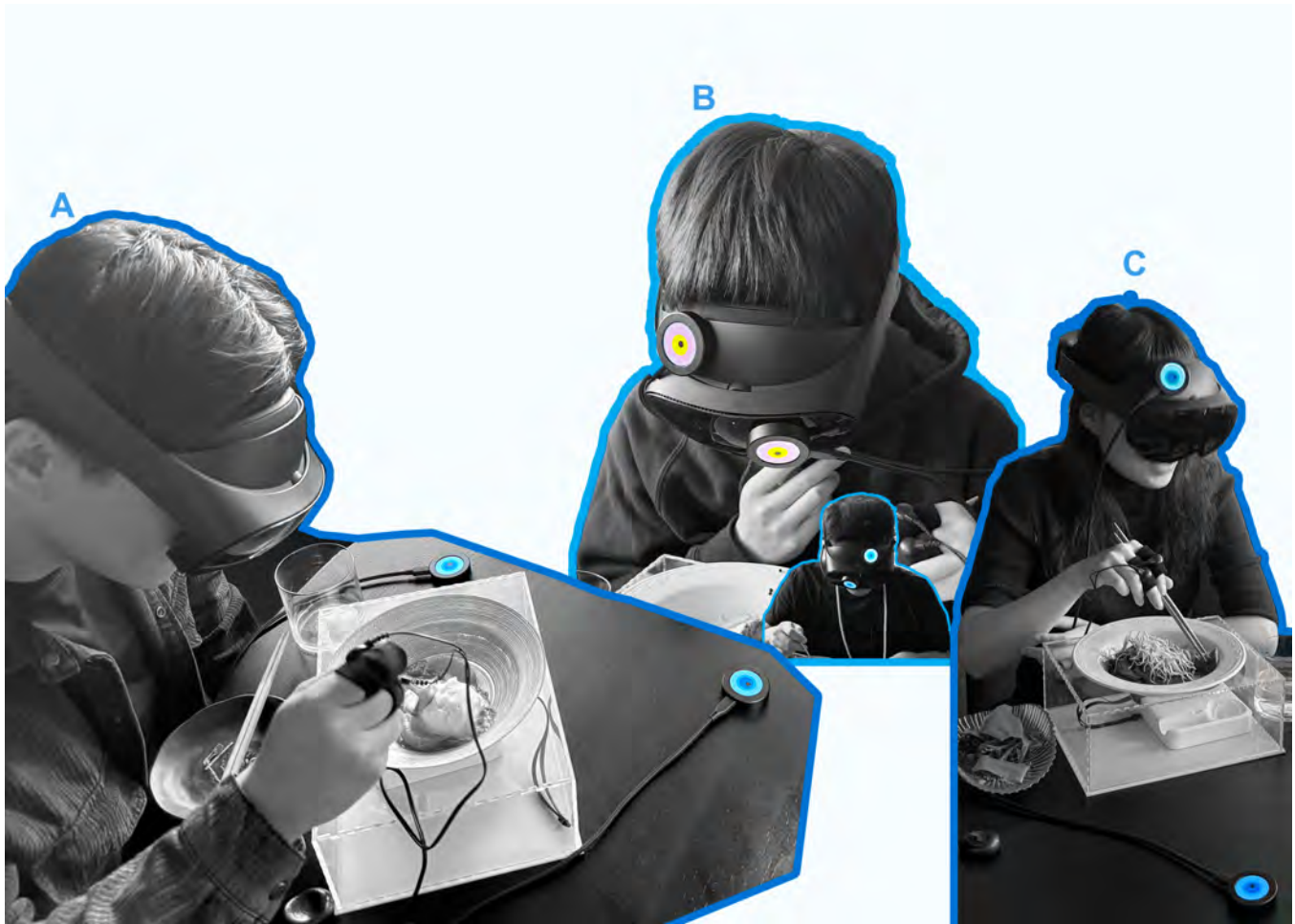

**Figure 10:** Collage of examples of different spatial placements of the external “Eyes” displays during dining: A) both displays placed on the table; B) both displays mounted on the XR headset; C) one display on the headset and one placed on the table.

the feeling that headset-wearing companions became “*absorbed in their own experience*,” resulting in fewer opportunities for direct interaction and shared conversation. D3 similarly reported ignoring or losing track of headset wearers, as they could not see their eyes or easily infer their state of engagement.

## 6 DISCUSSION

Our themes illustrate how XR food augmentations and externalized affective cues can shape social experience and interactional dynamics in co-located dining. In this section, we discuss how these findings extend prior work on crossmodal food experience, XR-mediated social interaction, performative interaction, and HFI, and distill six design considerations based on the craft knowledge gained through designing our system and our understanding of the associated user experiences, to inform future interaction design.

### 6.1 XR Food Augmentation Beyond Taste Modulation

We observe that in this real-world restaurant context, taste effects were not prominent (Theme 2). Across participants, visual and auditory augmentations were recognized as virtual (D2) and were rarely described as directly altering gustatory sensations. In contrast to prior laboratory-based studies, which have shown that visual and auditory cues can influence taste perception under controlled conditions [13, 40, 54, 67, 68, 77, 80], our findings suggest that such effects may not directly transfer to real-world restaurant dining contexts. One possible interpretation is that such effects may be context-dependent, and there is a contextual difference between controlled taste experiments and situated dining experiences, highlighting the need for further in-situ investigations.

We acknowledge that our XR augmentation designs did not replicate earlier crossmodal paradigms in a strictly manner. However, our design rationale was explicitly informed by prior crossmodal research, and the absence of taste-related effects persisted despite this grounding. Taken together, these findings suggest that while

crossmodal effects on taste are empirically robust in laboratory environments, their transferability to real-world restaurant contexts remains an open question. Additional in-the-wild studies are therefore needed to examine how, when, and for whom such effects might meaningfully manifest beyond the lab.

Based on our observations, we speculate that XR augmentations may be better suited for shaping experiential and social dimensions of dining, rather than functioning as direct taste modifiers:

*6.1.1 Design consideration 1: Consider XR augmentation as an experiential layer for a reconfigurable dining process.* Recent research in consumer and hospitality studies argues that contemporary restaurants should offer experience-centered, emotionally rich and memorable encounters rather than purely functional meals to remain competitive [55]. Our findings indicate that XR augmentations shaped diners' engagement in several ways (Theme 1). Specifically, we observed that they influenced attentional focus at the table (F1), shaped anticipation before eating (F2), and contributed to a playful, shared experience throughout the meal (F3). Based on these observations, we explore several design directions for restaurants to create "competitive" [55] meals. For instance, insights from F1 indicate that XR could possibly be used to design moments of heightened attentional focus at the table. Visual and auditory augmentations may be leveraged to mark transitions, frame dishes symbolically, or introduce reflective pauses. These could be aligned with festive occasions, seasonal themes, or narrative reveals—for example, dynamically presenting the meaning of a dish, its cultural background, or a message from the chef as part of the dining ritual.

Our tray-based design explored how XR could be integrated into existing service practices without requiring infrastructural change. Restaurants could appropriate similar spatial anchoring strategies to support dish-by-dish storytelling, synchronizing XR visuals, soundscapes and body movement with the courses. This approach resonates with precedents such as the "The Sound of the Sea" seafood dish of the Fat Duck restaurant [70], in which diners listen to ocean waves while eating, reinforcing the maritime narrative of the food. Our work tried to extend this dish design by showing that XR-driven visual augmentation (F1), soundscapes (F2) and body movement (F3) can function as an additional experiential layer, enriching narrative coherence.

## 6.2 Designing affective interfaces as performative resources in social dining

Our findings reveal the potential of the design of *E.A.T.* to function as a form of social performance (F4, F5). For instance, D6 described the external display as a social agent that supported their interaction with others. This resonates with the work of the twentieth-century sociologist Erving Goffman, who conceptualized everyday social interaction as a form of performance. Goffman argued that individuals continuously "perform" in front of others, and that social life can be understood as a theatrical stage [25]. He distinguished several key concepts:

- **Front stage:** the self that is intentionally presented to others, such as being kind among friends or well-behaved in front of relatives.

- **Back stage:** a space where individuals can temporarily drop their performance, including moments of complaint and emotional leakage.
- **Role:** not an inner essence, but a set of behaviors expected within a specific social situation.
- **Impression management:** the ongoing adjustment of speech, action, and expression to influence how one is perceived by others.

Commensality, as a form of social activity [15, 19, 29, 53], can thus be understood as a performance, where the dining table becomes a performance stage. Building on Goffman's framework and our system design, we now outline three design considerations for future designers aiming to support performativity in XR social dining contexts.

*6.2.1 Design consideration 2: Consider ambiguity as a design resource for biodata to support diners' front stage performance.* Our design employed ambiguous mappings between physiological arousal data and visual expression on the external display. Rather than presenting explicit emotional labels or direct interpretations (e.g., "liking"/"disliking," graph-based representations, or numbers), or replicating realistic human eyes (as seen in devices such as Apple Vision Pro), changes in color and pattern were used as expressive yet ambiguous signals. Findings from F4 indicate that this ambiguity enabled participants to engage in social interpretation and collective sense-making. Importantly, no participants reported a need for more precise emotional labels for the display to function socially. This observation resonates with Gaver et al.'s concept of ambiguity as a design resource that can support play and interpretation [23]. We further speculate that in social dining contexts characterized by performative interaction, ambiguous affective cues might be more appropriate than precise feedback, as they leave room for diners to perform on the "front stage" [25].

*6.2.2 Design consideration 3: Consider exaggeration to enrich performative expression.* Our design deliberately exaggerated affective expression through oversized eye representations (using a 32 millimeters circular display, compared to the typical human eyeball diameter of approximately 23 millimeters), amplified pupil movement, vivid color transitions, and dynamic patterns that exceed the subtlety of everyday ocular cues. These design choices were informed by prior HCI research on exaggerated expression [18, 24, 44, 46]. Such exaggeration has been shown to compensate for perceptual loss in human-machine interactions [24] and to mitigate the uncanny valley effect, as lower-fidelity representations often require greater exaggeration to convey emotional intensity comparable to real human faces [44].

In addition, our findings suggest that deviations from the normative spatial configuration of human eyes—namely, two horizontally aligned eyes symmetrically positioned on the face—can introduce humor (D6, Fig. 10B). This aligns with Goffman's claim that the face is a socially managed object [25].

Building on the above insight, and in light of the growing body of HFI work on multisensory design [12, 16, 80], we propose a future direction toward socially multisensory design for commensality. Prior HFI research has primarily examined how multisensory cues enhance individual taste perception, for example through systems

such as *immersiTea* [80], an XR experience that enriches bubble tea consumption through visual and auditory augmentation. In contrast, social dining opens up opportunities for multisensory expression that foreground interpersonal meaning. For instance, affective cues might be conveyed through olfactory channels, where emotional responses to food are externalized as interactive scents perceivable by co-diners, or through audiovisual modalities, in which “eyes” express emotion via coupled visual dynamics and musical or auditory signals. Such approaches could help compensate for the reduction of social cues in XR dining scenarios by distributing affective information across multiple sensory modalities. While our current system remains visually focused, we invite designers to explore commensality experiences that extend beyond visual presence and move toward interactions that go “beyond being there” [32].

Exaggeration may also be explored beyond the face by reconsidering the body itself as an expressive surface. Prior HCI work has framed the body as a canvas for digital information [31, 42, 43]. Given that bodily gestures and posture already function as key carriers of social meaning [4], future designs could investigate how technologically-driven exaggerated expressions distributed across the body—such as posture, movement, or spatially augmented body parts—might serve as additional social signals in commensality contexts.

Furthermore, the notion of exaggeration can be further extended through recent advances in generative AI. With the increasing maturity of AI-based image generation techniques [36], exaggerated affective expressions could be dynamically generated by combining generative models with richer streams of physiological data (e.g., heart rate variability, skin conductance), all while considering the ethical implications. Such an approach would allow for more adaptive and diverse visual representations of momentary affective states [10], expanding the design space of affect-expression mappings beyond fixed or predefined patterns, potentially aligning well with the dynamic, rich, and ephemeral character of commensality experiences.

**6.2.3 Design consideration 4: Consider removal as needed for a better social dining atmosphere.** Our design excluded explicit representations of negative valence (e.g., dislike, discomfort, or dissatisfaction). The four arousal states of the “Eyes” system progress from calm to heightened activation without encoding negative affect, aligning with dining as a culturally situated activity oriented toward enjoyment, togetherness, and social harmony. D2 explicitly noticed this design choice, while D3, who was grouped with D2, interpreted it as appropriate for a shared meal in which maintaining a pleasant interactional atmosphere was expected (F4). Diners’ accounts suggest that filtering out negative affect supported social comfort and reduced anxiety about being judged, rather than being perceived as a loss of expressiveness. In this sense, the display participated in the construction of a socially acceptable “table persona,” a “role” [25], allowing diners to manage how they were seen by others while maintaining a convivial atmosphere. Such selective visibility aligns with Goffman’s notion of impression management [25], as well as with existing products such as the *Qudi Mask*<sup>7</sup>, which frame

partiality and masking as essential to maintaining social interaction in social interfaces.

Nevertheless, we acknowledge that a fuller range of affective expression—including negative or ambivalent states—represents an important and underexplored design space.

We recommend that designers consider the strategic removal and addition of expressive dimensions as a design resource in social dining. In some situations, minimizing negative affect may be desirable to sustain harmony, while in others—such as moments of intentional disclosure or conflict negotiation—designers might deliberately surface otherwise suppressed expressions (e.g., calm yet clearly angry states), thereby selectively amplifying “back stage” [25] expressions. Designing such expressive dimensions to be personalizable could further empower users to align affective visibility with their social intentions and situational goals in commensal contexts.

To make this concept more concrete, consider the following common dining scenarios and how strategic removal might apply:

- **Scenario A: Friends catching up.** In this context, diners may want to share genuine reactions—including dislike or dissatisfaction—as part of authentic conversation. Here, a system might enable negative expression, but allow users to temporarily “mask” it (e.g., with a gesture or glance) if a sensitive topic arises.
- **Scenario B: Dining with strangers or acquaintances.** In more formal or less familiar settings, explicit negative signals could create social awkwardness. A system might filter out negative emotion by default.
- **Scenario C: Service interaction.** When interacting with restaurant staff, diners may prefer that affective displays remain private to avoid being evaluated or served differently. A system could automatically pause external display updates when a server approaches, or allow diners to toggle visibility with a simple interaction.

## 6.3 Reconstructing togetherness in co-located XR dining

Our findings suggest that togetherness in XR co-located dining is actively constructed through the external expressive displays (Theme 2). Participants’ interactions with the external displays, such as interpreting affective changes (F4), negotiating boundaries of affective visibility (F5), experiencing uneven expressive participation (F6), and physically reconfiguring display placement (F7), suggest that XR dining experiences are shaped by how affective cues are socially accessed and situated.

**6.3.1 Design consideration 5: Consider designing for bodily perception in XR social dining.** Diners reported that the externalized pupil movement and arousal cues fostered a heightened sense of being-with others (F4), suggesting that our system supported togetherness through embodied sociality by making biodata visible and socially perceivable. Togetherness thus emerged through a reciprocal loop of perceiving and being perceived. These findings align with prior HFI work *Arm-A-Dine* prototype [47], which achieves embodied sociality by attaching a robotic arm to each diner’s body and mapping one diner’s facial expressions to the other’s feeding actions.

<sup>7</sup><https://qudi.tech/pages/qudi-mask-2>

While *Arm-A-Dine* embeds sociality at the level of bodily action by reconfiguring eating movements across bodies [51], our system extends this line of work by demonstrating that embodied sociality can also be realized at the level of bodily perception. We propose that, in social dining contexts, bodily perception is as important as bodily action, as togetherness emerges not only from shared activities but from diners' continuous perceptual attunement to one another's bodily expressions [19, 75]. For researchers of social dining experiences, bodily perception could be considered an XR design concern, with attention given to how diners perceive and are perceived by others through subtle bodily cues.

**6.3.2 Design consideration 6: Consider configuring affective visibility for situated privacy in restaurant XR dining.** Our findings suggest that affective visibility introduced by the external displays is perceived as enjoyable yet potentially intrusive when they exceeds diners' desired social boundaries (F5). Diners described the external display as acceptable when affective cues were shared among friends (D1, D4), and reported that it fostered a sense of togetherness during the meal (D1, D2, D3, D7). However, achieving togetherness through the display of physiological signals was not desirable for all diners. Participants emphasized that such signals could be perceived as personal and private (D8), particularly in restaurant settings where affective displays could become visible to unintended audiences, including neighboring diners (D3) or restaurant staff (D8). This divergence in how affective visibility was experienced suggests that affective interfaces in dining contexts need to be designed around situated privacy. This result aligns with a growing body of affective computing research emphasizing that emotional data are inherently sensitive, thereby carrying privacy risks [17, 49].

Our diners also explored spatial configurations as a way of negotiating affective visibility (F7). For example, D8 placed one display on the table while keeping the other on their head, using the table-mounted display for personal reflection and the head-mounted one for sharing with co-diners. D9 moved both displays onto the table, noting that table-level placement better limited exposure to unintended audiences. Together, these practices raise questions about how social cues should be reconstructed in XR dining: rather than being faithfully reattached to their original bodily locations, affective cues in co-located settings can be spatially reconfigured to support situated privacy, allowing diners to dynamically control who can perceive their internal states and under what social conditions.

To better support HFI researchers in balancing togetherness and privacy when investigating XR co-located commensality, we articulate a framework defined by two orthogonal dimensions: degree of togetherness and publicness of experience (Fig. 11). The degree of togetherness captures how strongly diners are affectively and interactionally coupled during XR dining experiences. The publicness of experience describes the extent to which affective cues are perceptible to others beyond the wearer.

We position expressive displays mounted on the exterior of XR headsets, near the eyes (Fig. 9A), in the second quadrant, characterized by high togetherness and low privateness. In this configuration, affective expressions are readily visible to co-located diners,

thereby supporting social awareness and shared engagement. Although users may temporarily reduce visibility—for example, by covering the display with their hands or turning away—such actions require deliberate effort and do not fundamentally alter the public-facing nature of the display. In contrast, we position expressive displays embedded in the tabletop in the fourth quadrant (Fig. 10). This configuration affords relatively high togetherness while preserving higher privateness, as affective cues are spatially localized and allow diners to selectively control who can perceive social signals. Looking forward, we encourage HFI researchers to further explore alternative spatial configurations of expressive displays for XR dining, including integrations with tableware or other dining artifacts, to systematically examine how different placements mediate the trade-off between togetherness and privacy for XR co-located commensality.

## 7 LIMITATIONS AND FUTURE WORK

This work is subject to several limitations, which also point toward directions for future research and system development.

First, this study simultaneously introduced personalized food enhancement and social externalities, thereby limiting its capacity to isolate the origin of specific effects. For instance, it remains unclear whether the user's perceived senses arises from elaborate virtual decorations or from the novel form of social interaction. Future research should further disentangle the respective contributions of these two dimensions, for example, through A/B testing. Nevertheless, as an initial exploration, the present study prioritized ecological validity over experimental control. Also, in this study, we did not intend to measure the frequency of observed behaviors or the strength of patterns, because our current focus is on exploring other possibilities around the design of the system, rather than investigating which specific factors cause what behaviors. However, future work could consider measuring these aspects to test the generalizability of our findings or to compare the relative impact of different design choices.

A second limitation relates to the lack of direct food tracking. In the current implementation, the system does not track food objects. Instead, spatial alignment between virtual augmentations and food relies on a custom-designed tray with a controller as a fixed spatial anchor. This design choice was largely driven by technical constraints: at the time of system development, AR Foundation and related toolchains did not provide support for image tracking on Meta Quest headsets. If future Meta Quest devices or software frameworks support object recognition and image tracking, XR food augmentations could be anchored directly to the food itself. For example, edible symbols could be embedded into food using emerging fabrication methods such as 3D food printing or food-grade print pens, enabling object recognition or image tracking. This might ultimately lead to a point where the system knows how much food (and what kind) is put on every fork action, allowing to overlay every bite with its own individual augmentation. This could result in much more fine grained food augmentations that might enhance the user experience, extending our currently coarse approach. We hope that our work paves a way towards such a future.

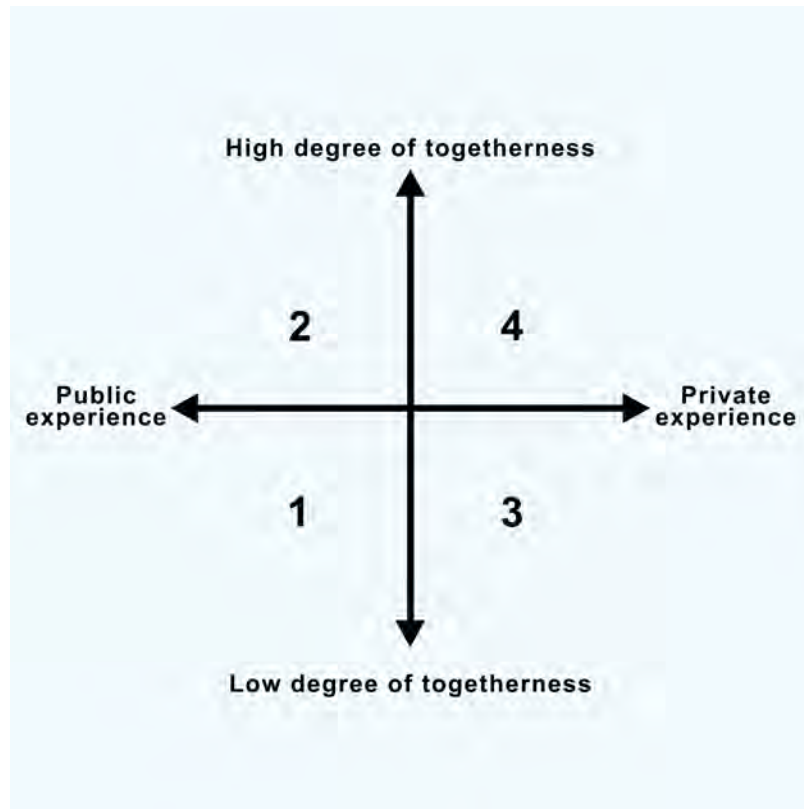

**Figure 11: A design space illustrating how XR dining experiences can vary along the dimensions of togetherness and publicness of experience.**

A third limitation relates to visual occlusion. As reflected in Theme 3, diners (D1, D2, D3, D4, D5, D8, D9) reported that XR augmentations sometimes obstructed visual access (F8) to food and interfered with social eating (F9). This highlights a broader challenge for XR food systems: balancing experiential augmentation with the practical demands of eating; rather than waiting for head-mounted displays to improve in clarity or functionality, it may be equally important to investigate how existing hardware constraints can be leveraged and optimized to maximize experiential value.

Another limitation of this work lies in its exploratory and qualitative methodology. As an early investigation of XR-mediated commensality in real restaurant settings, the study prioritizes situated experience, meaning-making, and social dynamics over controlled measurement, and therefore does not seek to quantify physiological, behavioral, or affective outcomes; although physiological signals were used for expressive feedback, they were not analyzed as measures of engagement or arousal. Consequently, the findings should be understood as generative insights rather than evidence of causal effects. Future research could extend this foundation through mixed-method designs that combine qualitative accounts with quantitative measures and controlled comparisons, enabling a shift from exploratory understanding toward more explanatory and evaluative claims. Furthermore, the system was studied in a short-term, novelty-driven context. While diners often described the experience

as playful and engaging, some questioned its long-term appeal. Future research should therefore examine how XR dining experiences might evolve over repeated use.

## 8 CONCLUSION

We aimed to broaden the scope of XR commensality by investigating how expressive XR systems can modulate co-located social dining in restaurants. Through the design of *E.A.T.*, we created an XR social dining system that integrates food augmentation with outward-facing affective biofeedback, and studied how diners interpreted and shaped their multisensory and social experiences. Our findings revealed key themes concerning attentional orchestration, affective sense-making, and the redistribution of social participation during shared meals. Based on these themes, we proposed design considerations for XR and HFI practitioners and researchers interested in supporting socially expressive and situated dining experiences. As an early-stage exploration, this work lays groundwork for future research on XR systems that support meaningful togetherness, contributing to broader discussions of eudaimonia in the digital age.

## Acknowledgments

We sincerely thank all the diners for their participation, and the reviewers for their time and effort in improving this paper. Florian

'Floyd' Mueller and Yuchen Zheng thank the Australian Research Council, especially DP190102068, DP200102612, and LP210200656 as well as Bansho Restaurant, Worksmith Pty Ltd and Grada Pty Ltd in Melbourne, Australia, for their continued support. Yuchen Zheng thanks Haopeng Wang from Lancaster University for his technical help and Don Samitha Elvitigala for introducing collaborators to this research.

## REFERENCES

- [1] Khawla Alhasan, Khaled Alhasan, Carlos Velasco, Ferran Altarriba Bertran, Moneim Ali, and Alexandra Covaci. 2025. Eating together apart: Designing immersive, multisensory commensality experiences in Virtual Reality. In *Proceedings of the 28th International Academic Mindtrek Conference (Mindtrek '25)*. Association for Computing Machinery, New York, NY, USA, 164–175. doi:10.1145/3757980.3757999
- [2] Khawla Alhasan, Eleonora Ceccaldi, Alexandra Covaci, Maurizio Mancini, Ferran Altarriba Bertran, Gijs Huisman, Mailin Lemke, and Chee Siang Ang. 2022. The Playful Potential of Digital Commensality: Learning from Spontaneous Playful Remote Dining Practices. *Proc. ACM Hum.-Comput. Interact.* 6, CHI PLAY, Article 254 (Oct. 2022), 24 pages. doi:10.1145/3549517
- [3] Jeanine Ammann, Christina Hartmann, Vega Peterhans, Sandro Ropelato, and Michael Siegrist. 2020. The relationship between disgust sensitivity and behaviour: A virtual reality study on food disgust. *Food Quality and Preference* 80 (2020), 103833. doi:10.1016/j.foodqual.2019.103833
- [4] Michael Argyle. 1988. *Bodily Communication* (2 ed.). Routledge, London. 384 pages. doi:10.4324/9780203753835 eBook published 2013.
- [5] Peter Arnold, Rohit Ashok Khot, and Florian 'Floyd' Mueller. 2018. "You Better Eat to Survive": Exploring Cooperative Eating in Virtual Reality Games. In *Proceedings of the Twelfth International Conference on Tangible, Embedded, and Embodied Interaction* (Stockholm, Sweden) (TEI '18). Association for Computing Machinery, New York, NY, USA, 398–408. doi:10.1145/3173225.3173238
- [6] Elin A. Björling, Ada Kim, Katelynn Oleson, and Patrícia Alves-Oliveira. 2022. I Am the Robot: Teen Collaboration in an Asymmetric, Virtual Reality Game. *Frontiers in Virtual Reality* 2 (2022), 746521. doi:10.3389/frvir.2021.746521
- [7] Virginia Braun and Victoria Clarke. 2019. Reflecting on reflexive thematic analysis. *Qualitative Research in Sport, Exercise and Health* 11 (06 2019), 1–9.
- [8] Victor Bréhault, Emmanuel Dubois, Arnaud Prouzeau, and Marcos Serrano. 2025. A Systematic Literature Review to Characterize Asymmetric Interaction in Collaborative Systems. In *Proceedings of the 2025 CHI Conference on Human Factors in Computing Systems (CHI '25)*. Association for Computing Machinery, New York, NY, USA, Article 704, 19 pages. doi:10.1145/3706598.3713129
- [9] Jas Brooks, Noor Amin, and Pedro Lopes. 2023. Taste Retargeting via Chemical Taste Modulators. In *Proceedings of the 36th Annual ACM Symposium on User Interface Software and Technology* (San Francisco, CA, USA) (UIST '23). Association for Computing Machinery, New York, NY, USA, Article 106, 15 pages. doi:10.1145/3586183.3606818
- [10] Kuan-Ning Chang, Yu-Hin Chan, Jung Shen, Meng-Wei Lu, Tse-Yu Pan, and Ping-Hsuan Han. 2025. Avacard: Exercise Data-Driven AI-Generated Cards to Enhance Interactivity for Extended Reality Exergame through Metagame. In *2025 IEEE International Symposium on Mixed and Augmented Reality Adjunct (ISMAR-Adjunct)*. 966–967. doi:10.1109/ISMAR-Adjunct68609.2025.00270
- [11] Weijen Chen, Qingyuan Gao, Zheng Hu, Kouta Minamizawa, and Yun Suen Pai. 2025. Living Bento: Heartbeat-Driven Noodles for Enriched Dining Dynamics. In *Proceedings of the 2025 CHI Conference on Human Factors in Computing Systems (CHI '25)*. Association for Computing Machinery, New York, NY, USA, Article 353, 18 pages. doi:10.1145/3706598.3713108
- [12] Weijen Chen, Yang Yang, Kao-Hua Liu, Yun Suen Pai, Junichi Yamaoka, and Kouta Minamizawa. 2024. Cymatics Cup: Shape-Changing Drinks by Leveraging Cymatics. In *Proceedings of the 2024 CHI Conference on Human Factors in Computing Systems* (Honolulu, HI, USA) (CHI '24). Association for Computing Machinery, New York, NY, USA, Article 861, 19 pages. doi:10.1145/3613904.3642920
- [13] Yang Chen, Arya Xinran Huang, Ilona Faber, Guido Makransky, and Federico J. A. Perez-Cueto. 2020. Assessing the Influence of Visual-Taste Congruency on Perceived Sweetness and Product Liking in Immersive VR. *Foods* 9, 4 (2020), doi:10.3390/foods9040465
- [14] Yumiao Chen, Xin Wang, and Huijia Xu. 2021. Human factors/ergonomics evaluation for virtual reality headsets: a review. *CCF Transactions on Pervasive Computing and Interaction* 3 (06 2021), 99–111. doi:10.1007/s42486-021-00062-6
- [15] Sara Delamont. 1995. *Appetites and Identities: An Introduction to the Social Anthropology of Western Europe* (1 ed.). Routledge, London. 272 pages. doi:10.4324/9780203413517
- [16] Jialin Deng, Yinyi Li, Hongyue Wang, Ziqi Fang, and Florian 'Floyd' Mueller. 2025. Sonic Delights: Exploring the Design of Food as An Auditory-Gustatory Interface. In *Proceedings of the 2025 CHI Conference on Human Factors in Computing Systems (CHI '25)*. Association for Computing Machinery, New York, NY, USA, Article 356, 19 pages. doi:10.1145/3706598.3713892
- [17] Laurence Devillers and Roddy Cowie. 2023. Ethical Considerations on Affective Computing: An Overview. *Proc. IEEE* 111, 10 (2023), 1445–1458. doi:10.1109/JPROC.2023.3315217
- [18] Georgiana Cristina Dobre, Marta Wilczkowiak, Marco Gillies, Xueni Pan, and Sean Rintel. 2025. Avatars in mixed-reality meetings: A longitudinal field study of realistic versus cartoon facial likeness effects on communication, task satisfaction, presence, and emotional perception. *International Journal of Human-Computer Studies* 205 (2025), 103632. doi:10.1016/j.ijhcs.2025.103632
- [19] R. I. M. Dunbar. 2017. Breaking Bread: the Functions of Social Eating. *Adaptive Human Behavior and Physiology* 3 (2017), 198–211. doi:10.1007/s40750-017-0061-4
- [20] Anna Felnhöfer, Franziska Pfannenstill, Lisa Gänsler, Oswald D. Kothgassner, Elke Humer, Johanna Büttner, and Thomas Probst. 2025. Barriers to adopting therapeutic virtual reality: the perspective of clinical psychologists and psychotherapists. *Frontiers in Psychiatry* 16 (2025), 1549090. doi:10.3389/frpsyt.2025.1549090
- [21] Hunter Fong, Selim Soufargi, Maurizio Mancini, and Radoslaw Niewiadomski. 2025. *Designing Interactions for Artificial Commensal Companions*. Association for Computing Machinery, New York, NY, USA, 306–311. https://doi.org/10.1145/3715668.3736351
- [22] Jayne A. Fulkerson, Mary Story, Alison Mellin, Nancy Leffert, Dianne Neumark-Sztainer, and Simone A. French. 2006. Family Dinner Meal Frequency and Adolescent Development: Relationships with Developmental Assets and High-Risk Behaviors. *Journal of Adolescent Health* 39, 3 (2006), 337–345. doi:10.1016/j.jadohealth.2005.12.026
- [23] William W. Gaver, Jacob Beaver, and Steve Benford. 2003. Ambiguity as a resource for design. In *Proceedings of the SIGCHI Conference on Human Factors in Computing Systems* (Ft. Lauderdale, Florida, USA) (CHI '03). Association for Computing Machinery, New York, NY, USA, 233–240. doi:10.1145/642611.642653
- [24] Michael J. Gielniak and Andrea L. Thomaz. 2012. Enhancing interaction through exaggerated motion synthesis. In *Proceedings of the Seventh Annual ACM/IEEE International Conference on Human-Robot Interaction* (Boston, Massachusetts, USA) (HRI '12). Association for Computing Machinery, New York, NY, USA, 375–382. doi:10.1145/2157689.2157813
- [25] Erving Goffman. 1959. *The Presentation of Self in Everyday Life*. Anchor Books.
- [26] Catherine Grevet, Anthony Tang, and Elizabeth Mynatt. 2012. Eating alone, together: new forms of commensality. In *Proceedings of the 2012 ACM International Conference on Supporting Group Work* (Sanibel Island, Florida, USA) (GROUP '12). Association for Computing Machinery, New York, NY, USA, 103–106. doi:10.1145/2389176.2389192
- [27] Jan Gugenheimer, Evgeny Stemasov, Julian Frommel, and Enrico Rukzio. 2017. ShareVR: Enabling Co-located Experiences for Virtual Reality between HMD and Non-HMD Users. In *Proceedings of the 2017 CHI Conference on Human Factors in Computing Systems* (Denver, Colorado, USA) (CHI '17). Association for Computing Machinery, New York, NY, USA, 4021–4033. doi:10.1145/3025453.3025683
- [28] Jan Gugenheimer, Evgeny Stemasov, Harpreet Sareen, and Enrico Rukzio. 2018. FaceDisplay: Towards Asymmetric Multi-User Interaction for Nomadic Virtual Reality. In *Proceedings of the 2018 CHI Conference on Human Factors in Computing Systems* (Montreal QC, Canada) (CHI '18). Association for Computing Machinery, New York, NY, USA, 1–13. doi:10.1145/3173574.3173628
- [29] Suzanne Higgs. 2015. Social norms and their influence on eating behaviours. *Appetite* 86 (2015), 38–44. doi:10.1016/j.appet.2014.10.021 Social Influences on Eating.
- [30] Linda Hirsch, Florian Müller, Francesco Chiossi, Theodor Benga, and Andreas Martin Butz. 2023. My Heart Will Go On: Implicitly Increasing Social Connectedness by Visualizing Asynchronous Players' Heartbeats in VR Games. *Proc. ACM Hum.-Comput. Interact.* 7, CHI PLAY, Article 411 (Oct. 2023), 26 pages. doi:10.1145/3611057
- [31] Thuong N. Hoang, Hasan S. Ferdous, Frank Vetere, and Martin Reinoso. 2018. Body as a Canvas: An Exploration on the Role of the Body as Display of Digital Information. In *Proceedings of the 2018 Designing Interactive Systems Conference* (Hong Kong, China) (DIS '18). Association for Computing Machinery, New York, NY, USA, 253–263. doi:10.1145/3196709.3196724
- [32] Jim Hollan and Scott Stornetta. 1992. Beyond being there. In *Proceedings of the SIGCHI Conference on Human Factors in Computing Systems* (Monterey, California, USA) (CHI '92). Association for Computing Machinery, New York, NY, USA, 119–125. doi:10.1145/142750.142769
- [33] Lun-Kai Hsu, Wen-Sheng Tseng, Li-Wei Kang, and Yu-Chiang Frank Wang. 2013. Seeing through the Expression: Bridging the Gap between Expression and Emotion Recognition. In *Proceedings of the IEEE International Conference on Multimedia and Expo (ICME)*. 1–6. doi:10.1109/ICME.2013.6607638
- [34] Andrew Irlitti, Mesut Latifoglu, Qiushi Zhou, Martin N Reinoso, Thuong Hoang, Eduardo Velloso, and Frank Vetere. 2023. Volumetric Mixed Reality Telepresence for Real-time Cross Modality Collaboration. In *Proceedings of the 2023 CHI Conference on Human Factors in Computing Systems* (Hamburg, Germany) (CHI '23). Association for Computing Machinery, New York, NY, USA, Article 101, 14 pages. doi:10.1145/3544548.3581277

- [35] Pascal Jansen, Fabian Fischbach, Jan Gugenheimer, Evgeny Stemasov, Julian Frommel, and Enrico Rukzio. 2020. ShARe: Enabling Co-Located Asymmetric Multi-User Interaction for Augmented Reality Head-Mounted Displays. In *Proceedings of the 33rd Annual ACM Symposium on User Interface Software and Technology* (Virtual Event, USA) (UIST '20). Association for Computing Machinery, New York, NY, USA, 459–471. doi:10.1145/3379337.3415843
- [36] Zhen Jia, Zhang Zhang, Liang Wang, and Tieniu Tan. 2024. Human Image Generation: A Comprehensive Survey. *ACM Comput. Surv.* 56, 11, Article 279 (June 2024), 39 pages. doi:10.1145/3665869
- [37] Rohit Ashok Khot and Florian Mueller. 2019. Human-Food Interaction. *Foundations and Trends® in Human-Computer Interaction* 12, 4 (2019), 238–415. doi:10.1561/1100000074
- [38] Rohit Ashok Khot and Florian Mueller. 2019. *Human-Food Interaction*. Foundations and Trends® in Human-Computer Interaction Series, Vol. 12. Now Publishers. 238–415 pages. <https://books.google.com.au/books?id=meE8xQEACAAJ>
- [39] Simon Kimmel, Frederike Jung, Andrii Matvienko, Wilko Heuten, and Susanne Boll. 2023. Let's Face It: Influence of Facial Expressions on Social Presence in Collaborative Virtual Reality. In *Proceedings of the 2023 CHI Conference on Human Factors in Computing Systems* (Hamburg, Germany) (CHI '23). Association for Computing Machinery, New York, NY, USA, Article 429, 16 pages. doi:10.1145/3544548.3580707
- [40] Rebecca Kleinberger, Akito Oshiro Van Troyer, and Qian Janice Wang. 2023. Auditory Seasoning Filters: Altering Food Perception via Augmented Sonic Feedback of Chewing Sounds. In *Proceedings of the 2023 CHI Conference on Human Factors in Computing Systems* (Hamburg, Germany) (CHI '23). Association for Computing Machinery, New York, NY, USA, Article 318, 15 pages. doi:10.1145/3544548.3580755
- [41] Shuqing Li, Qisheng Zheng, Cuiyun Gao, Jia Feng, and Michael R. Lyu. 2025. Extended Reality Cybersickness Assessment via User Review Analysis. *Proc. ACM Softw. Eng.* 2, ISSTA, Article ISSTA058 (June 2025), 23 pages. doi:10.1145/3728933
- [42] Zhuying Li, Jacob Sheahan, Yan Wang, Stefan Greuter, and Florian 'Floyd' Mueller. 2019. InsideOut: Playing with Real-time Video Images of the Gastrointestinal Tract via Imaging Capsules. In *Extended Abstracts of the Annual Symposium on Computer-Human Interaction in Play Companion Extended Abstracts* (Barcelona, Spain) (CHI PLAY '19 Extended Abstracts). Association for Computing Machinery, New York, NY, USA, 501–509. doi:10.1145/3341215.3356291
- [43] Zhuying Li, Yan Wang, Josh Andres, Nathan Semertzidis, Stefan Greuter, and Florian Mueller. 2023. A Design Framework for Ingestible Play. *ACM Trans. Comput.-Hum. Interact.* 30, 4, Article 58 (Sept. 2023), 39 pages. doi:10.1145/3589954
- [44] Meeri Mäkäräinen, Jari Kätsyri, and Tapio Takala. 2014. Exaggerating Facial Expressions: A Way to Intensify Emotion or a Way to the Uncanny Valley? *Cognitive Computation* 6 (2014), 708–721. doi:10.1007/s12559-014-9273-0
- [45] Maurizio Mancini, Conor Patrick Gallagher, Radoslaw Niewiadomski, Gijs Huisman, and Merijn Bruijnes. 2020. Introducing Artificial Commensal Companions. In *Proceedings of the 2020 International Conference on Advanced Visual Interfaces* (Salerno, Italy) (AVI '20). Association for Computing Machinery, New York, NY, USA, Article 89, 3 pages. doi:10.1145/3399715.3399958
- [46] Rachel McDonnell, Martin Breidt, and Heinrich H. Bühlhoff. 2012. Render me real? investigating the effect of render style on the perception of animated virtual humans. *ACM Trans. Graph.* 31, 4, Article 91 (July 2012), 11 pages. doi:10.1145/2185520.2185587
- [47] Yash Dhanpal Mehta, Rohit Ashok Khot, Rakesh Patibanda, and Florian 'Floyd' Mueller. 2018. Arm-A-Dine: Towards Understanding the Design of Playful Embodied Eating Experiences. In *Proceedings of the 2018 Annual Symposium on Computer-Human Interaction in Play* (Melbourne, VIC, Australia) (CHI PLAY '18). Association for Computing Machinery, New York, NY, USA, 299–313. doi:10.1145/3242671.3242710
- [48] Ana Mengual-Recuerda, Victoria Tur-Viñes, and David Juárez-Varón. 2020. Neuromarketing in Haute Cuisine Gastronomic Experiences. *Frontiers in Psychology* 11 (2020), 1772. doi:10.3389/fpsyg.2020.01772
- [49] Deepa Mishra, Sonali Deshpande, Mallikarjuna Anna Gupta, and Anupriya Tiwari. 2024. *Exploring the Ethical Dimensions and Societal Consequences of Affective Computing*. Springer Nature Switzerland, Cham, 91–105. doi:10.1007/978-3-031-63821-3\_5
- [50] Clara Moge, Katherine Wang, and Youngjun Cho. 2022. Shared User Interfaces of Physiological Data: Systematic Review of Social Biofeedback Systems and Contexts in HCI. In *Proceedings of the 2022 CHI Conference on Human Factors in Computing Systems* (New Orleans, LA, USA) (CHI '22). Association for Computing Machinery, New York, NY, USA, Article 301, 16 pages. doi:10.1145/3491102.3517495
- [51] Florian 'Floyd' Mueller, Oğuz 'Oz' Buruk, Louise Petersen Matjeka, and Aryan Saini. 2025. Towards understanding the design of playful bodily extensions via body schema and body image. *International Journal of Human-Computer Studies* 197 (2025), 103457. doi:10.1016/j.ijhcs.2025.103457
- [52] Florian 'Floyd' Mueller, Marianna Obrist, Ferran Altarriba Bertran, Neharika Makam, Soh Kim, Christopher Dawes, Patrizia Marti, Maurizio Mancini, Eleonora Ceccaldi, Nandini Pasumarthy, Sahej Claire, Kyung seo Jung, Jialin Deng, Jürgen Steimle, Nadejda Krasteva, Matti Schwalk, Harald Reiterer, Hongyue Wang, and Yan Wang. 2024. Grand challenges in human-food interaction. *International Journal of Human-Computer Studies* 183 (2024), 103197. doi:10.1016/j.ijhcs.2023.103197
- [53] J. Mäkelä. 2009. 3 - Meals: the social perspective. In *Meals in Science and Practice*, Herbert L. Meiselman (Ed.). Woodhead Publishing, 37–49. doi:10.1533/9781845695712.2.37
- [54] Takuji Narumi, Shinya Nishizaka, Takashi Kajinami, Tomohiro Tanikawa, and Michitaka Hirose. 2011. MetaCookie+. In *2011 IEEE Virtual Reality Conference*. 265–266. doi:10.1109/VR.2011.5759500
- [55] Nurul Ain Natrah Jamaludin and Nik Mohd Hazrul Nik Hashim. 2025. Tasting Emotions: How Hedonic Emotions, Experience, and Psychological Traits Amplify Fine Dining Post-Consumption Behaviors. *Journal of Sensory Studies* 40, 6 (2025), e70091. doi:10.1111/joss.70091 First published 24 November 2025.
- [56] Radoslaw Niewiadomski, Merijn Bruijnes, Gijs Huisman, Conor Patrick Gallagher, and Maurizio Mancini. 2022. Social robots as eating companions. *Frontiers in Computer Science* Volume 4 - 2022 (2022). doi:10.3389/fcomp.2022.909844
- [57] Marianna Obrist, Yunwen Tu, Lining Yao, and Carlos Velasco. 2019. Space Food Experiences: Designing Passenger's Eating Experiences for Future Space Travel Scenarios. *Frontiers in Computer Science* Volume 1 - 2019 (2019). doi:10.3389/fcomp.2019.00003
- [58] Marianna Obrist and Carlos Velasco. 2025. Multisensory Experiences: Formation, Realization, and Responsibilities. *Commun. ACM* 68, 4 (March 2025), 50–59. doi:10.1145/3699594
- [59] Kaitlyn Ouverson, Norene Kelly, and Stephen B. Gilbert. 2017. Fashion and Technology: Implications for the Social Acceptability of a Wearable Device. In *Human-Computer Interaction. User Interface Design, Development and Multimodality*, Masaaki Kurosu (Ed.). Springer International Publishing, Cham, 203–213. doi:10.1007/978-3-319-58071-5\_16
- [60] Stephen E. Palmer and Karen B. Schloss. 2010. An ecological valence theory of human color preference. *Proceedings of the National Academy of Sciences* 107, 19 (2010), 8877–8882. doi:10.1073/pnas.0906172107
- [61] Victoria Peng. 2021. Wigglears: Wiggle Your Ears With Your Emotions. In *Extended Abstracts of the 2021 CHI Conference on Human Factors in Computing Systems* (Yokohama, Japan) (CHI EA '21). Association for Computing Machinery, New York, NY, USA, Article 492, 5 pages. doi:10.1145/3411763.3451846
- [62] Mirjana Prpa, Sarah Fdili-Alaoui, Thecla Schiphorst, and Philippe Pasquier. 2020. Articulating Experience: Reflections from Experts Applying Micro-Phenomenology to Design Research in HCI. In *Proceedings of the 2020 CHI Conference on Human Factors in Computing Systems* (CHI '20). Association for Computing Machinery, New York, NY, USA, 1–14. doi:10.1145/3313831.3376664
- [63] Helen K Ruddock, Jeffrey M Brunstrom, Lenny R Vartanian, and Suzanne Higgs. 2019. A systematic review and meta-analysis of the social facilitation of eating. *The American Journal of Clinical Nutrition* 110, 4 (2019), 842–861. doi:10.1093/ajcn/nqz155
- [64] Andrés Santos-Torres, Patricia de Torres Coll, Tamás Bukits, Ramón Perisé, and Sergio Cabrero Barros. 2025. The XR Table: Envisioning The Future of Remote Dining Experiences Using Immersive Telepresence. In *Proceedings of the 2025 ACM Designing Interactive Systems Conference (DIS '25)*. Association for Computing Machinery, New York, NY, USA, 1674–1690. doi:10.1145/3715336.3735730
- [65] Dimitrios Saredakis, Ancret Szpak, Brandon Birckhead, Hannah A. D. Keage, Albert Rizzo, and Tobias Loetscher. 2020. Factors Associated With Virtual Reality Sickness in Head-Mounted Displays: A Systematic Review and Meta-Analysis. *Frontiers in Human Neuroscience* 14 (2020), 96. doi:10.3389/fnhum.2020.00096
- [66] Kosuke Shimizu, Max Hanssen, Jackie Shepherd, and Seung Hee Lee. 2025. Emotion Bridge Design Workshop with My Daily Badge. *International Symposium on Affective Science and Engineering ISASE2025* (2025), 1–3. doi:10.5057/isase.2025-C000040
- [67] Charles Spence. 2015. Multisensory Flavor Perception. *Cell* 161, 1 (2015), 24–35. doi:10.1016/j.cell.2015.03.007
- [68] Charles Spence. 2023. Digitally enhancing tasting experiences. *International Journal of Gastronomy and Food Science* 32 (June 2023), 100695. doi:10.1016/j.ijgfs.2023.100695
- [69] Charles Spence, Maurizio Mancini, and Gijs Huisman. 2019. Digital Commensality: Eating and Drinking in the Company of Technology. *Frontiers in Psychology* Volume 10 - 2019 (2019). doi:10.3389/fpsyg.2019.02252
- [70] Charles Spence and Betina Piqueras-Fiszman. 2013. Technology at the dining table. *Flavour* 2 (02 2013). doi:10.1186/2044-7248-2-16
- [71] Charles Spence and Carlos Velasco. 2025. *Digital Commensality*. Springer Nature Switzerland, Cham, 125–151. doi:10.1007/978-3-031-91050-0\_5
- [72] S. Spinelli, L. Pierguidi, G. Gavazzi, C. Dinnella, A. De Toffoli, J. Prescott, and E. Monteleone. 2023. Skin conductance responses to oral stimuli: The role of taste quality and intensity, and personality traits. *Food Quality and Preference* 109 (2023), 104917. doi:10.1016/j.foodqual.2023.104917
- [73] Constantine Stephanidis, Gavriel Salvendy, Margherita Antona, Jessie Y. C. Chen, Jianming Dong, Vincent G. Duffy, Xiaowen Fang, Cali Fidopiastis, Gino Fragomeni, Limin Paul Fu, Yinni Guo, Don Harris, Andri Ioannou, Kyeong ah (Kate) Jeong, Shin'ichi Konomi, Heidi Krömker, Masaaki Kurosu, James R. Lewis,

- Aaron Marcus, Gabriele Meiselwitz, Abbas Moallem, Hirohiko Mori, Fiona Fui-Hoon Nah, Stavroula Ntoa, Pei-Luen Patrick Rau, Dylan Schmorow, Keng Siau, Norbert Streitz, Wentao Wang, Sakae Yamamoto, Panayiotis Zaphiris, and Jia Zhou. 2019. Seven HCI Grand Challenges. *International Journal of Human-Computer Interaction* 35, 14 (2019), 1229–1269. doi:10.1080/10447318.2019.1619259
- [74] Jennifer Utter, Simon Denny, Elizabeth Robinson, Theresa Fleming, Shanthi Ameratunga, and Sue Grant. 2013. Family meals and the well-being of adolescents. *Journal of Paediatrics and Child Health* 49, 11 (2013), 906–911. doi:10.1111/jpc.12428
- [75] Amy van der Heijden and Sally Wiggins. 2025. Interaction as the foundation for eating practices in shared mealtimes. *Appetite* 205 (2025), 107585. doi:10.1016/j.appet.2024.107585 Editorial; Epub 29 June 2024.
- [76] Carlos Velasco, Francisco Barbosa Escobar, Olivia Petit, and Qian Janice Wang. 2021. Impossible (Food) Experiences in Extended Reality. *Frontiers in Computer Science* 3 (Aug. 2021). doi:10.3389/fcomp.2021.716846
- [77] Qian Janice Wang, Rachel Meyer, Stuart Waters, and David Zendle. 2020. A Dash of Virtual Milk: Altering Product Color in Virtual Reality Influences Flavor Perception of Cold-Brew Coffee. *Frontiers in Psychology* 11 (Dec. 2020). doi:10.3389/fpsyg.2020.595788
- [78] Jun Wei, Xuan Wang, Roshan Lalintha Peiris, Yongsoo Choi, Xavier Roman Martinez, Remi Tache, Jeffrey Tzu Kwan Valino Koh, Veronica Halupka, and Adrian David Cheok. 2011. CoDine: an interactive multi-sensory system for remote dining. In *Proceedings of the 13th International Conference on Ubiquitous Computing* (Beijing, China) (*UbiComp '11*). Association for Computing Machinery, New York, NY, USA, 21–30. doi:10.1145/2030112.2030116
- [79] Zihang Yin, Shiqian Wu, Zhonghua Wan, Bo Yang, Sos Aгаian, and Xiao Sun. 2025. Fuzzy Naive Bayes with Gaze-Behavior-Aware Attention for Accurate Intention Inference. *Expert Systems with Applications* 299 (2025), 130152. doi:10.1016/j.eswa.2025.130152
- [80] Yuchen Zheng, Jialin Deng, Hongyue Wang, Florian 'Floyd' Mueller, Xueni Pan, and Marco Fyfe Pietro Gillies. 2025. immersiTea: Exploring Multisensory Virtual Reality Environments to Enrich Bubble Tea Drinking Experiences. In *Proceedings of the Extended Abstracts of the CHI Conference on Human Factors in Computing Systems (CHI EA '25)*. Association for Computing Machinery, New York, NY, USA, Article 613, 7 pages. doi:10.1145/3706599.3720228
- [81] Yuchen Zheng, Zhuo Wang, Hongyue Wang, Don Samitha Elvitigala, and Florian "Floyd" Mueller. 2026. Towards Understanding the Design of Mixed Reality Systems to Enrich the Beverage Experience. In *Proceedings of the 2026 CHI Conference on Human Factors in Computing Systems (CHI '26)*. Association for Computing Machinery, New York, NY, USA, 23. doi:10.1145/3772318.3790615

## A Summary of XR food augmentation ideas brainstorming

**Table 4: Quadrants of the Reality–Impossibility model with example effects.**

Quadrant	Description	Example Effects
<b>Q1. Physical Reality</b> ( <i>real world + real physics</i> )	Small, believable sensory boosts — things that <i>could</i> happen in real life.	Adding salt crystals Chilli appeared in food Lemon appeared in food Chocolate crumbs or flakes falling Cream on top of dessert Juicy reflection on meat Ice cube in drinks Parsley on the surface of the food Adding pepper Mint on food
<b>Q2. Other Reality</b> ( <i>real world + breaks physics</i> )	Real food, but with impossible motion or timing.	Steam rising from food Salt grains float upward and fall back Lemon slice reverses time — juice flows back in Chocolate swirl levitates and reshapes Cream drip freezes mid-air Steam forms geometric shapes Ice hovers above drink Soup bubbles play sound notes Food rebuilds itself after bite Gravity bends around plate
<b>Q3. Physical Fantasy</b> ( <i>fantasy look + real physics</i> )	Imaginary or symbolic foods, but still obey gravity and realism.	Crystal-shaped salt blocks glowing faintly Golden chilli vines growing around plate Lemon sun or citrus planet hovering <i>just above</i> Chocolate river flowing through plate Cream clouds that puff when touched Seasonal blossoms growing near dish The aurora emanated from the food Animated bees gathering honey Fairy dust sprinkles (but fall realistically) Moonlight reflection on soup surface
<b>Q4. Other Fantasy</b> ( <i>fantasy world + breaks physics</i> )	Total imagination — dream-world dining, breaking every rule.	Food turns into glowing energy orb Bite releases stars or galaxies Chocolate comet orbiting the table Lemon sun explodes into light Cream transforms into clouds carrying you up Chilli dragons flying out of bowl Salt becomes snowstorm Steam forms spirits or faces Table floats in space You become the food or planet